



8

Transformer Equipment



					
600V Pg.207	1.1Kv Pg.208	1.1Kv Pg.208	3.6Kv Pg.209	12Kv Pg.209	24Kv Pg.210
					
36Kv Pg.210	Air-to-air Pg.211	Cable box Pg.211	DIN Pg.212	EN Pg.213	AU Pg.214 - 215
					
Offset Bushings Pg.216	Wildlife Guards Pg.216	Rotary Tap Switches Pg.217	Rotary Tap Switches Pg.218	Rotary Tap Switches Pg.219	Rotary Tap Switches Pg.220
					
Rotary Tap Switches Pg.221	Linear Tap Switches Pg.221	Rotary Tap Switches Pg.222	Oil Gauges Pg.223	Ball Valve Pg.223	Ball Valve Pg.224
					
Brass Plug Pg.224	Radiator Valve Pg.224	Weld On Boss Pg.224	Breathers Pg.225	Thermometers BM80 Pg.227	Thermometers with Contacts Pg.227
					
Thermometer F036 Pg.228	Pocket Housing and Boss Assembly Pg.228	Buchholz Relays Pg.229	Pressure Relief Valve Pg.235	Magnetic Oil Gauges Pg.238	

600V Terminal Immersed Bushings



PART NUMBER	DESCRIPTION	Kv RATING	CURRENT RATING	MATERIAL	TANK HOLE SIZE
040-006	B6	0.6	45	PA6 Black Nylon	15
040-035	BS6	0.6	45	PA6 Black Nylon	12
040-007	B8	0.6	60	PA6 Black Nylon	21
040-008	B10	0.6	80	DMC	22
040-009	B12	0.6	120	DMC	25
040-025	NB6	0.6	45	DMC	19
040-026	NB8	0.6	60	DMC	19
040-034	NB8 - 3.3	3.3	60	DMC	19
040-027	NB10	0.6	80	DMC	22

* Note: Detailed drawings available on request

Enclosures

Hinges

Locks

Handles

Accessories

Rotary Operating
Handles

Insulators

Transformer
Equipment

Index

1.1Kv Outdoor Immersed Bushings



PART NUMBER	DESCRIPTION	Kv RATING	CURRENT RATING	TANK HOLE SIZE
040-322	SAD120	1.1	120	31
040-312	SX160	1.1	160	31
040-323	SAD250	1.1	250	31
040-324	SAD330	1.1	330	31
040-315	SB500	1.1	500	45
040-316	SB630	1.1	630	45
040-326	SBD630	1.1	630	40
040-317	SC850 + Brass Flag	1.1	850	50
040-318	SC1250 + Brass Flag	1.1	1250	50
040-361	SD1600 + Brass Flag	1.1	1600	70
040-320	SD2500 + Brass Flag	1.1	2500	70
040-319	SD2900 + Brass Flag	1.1	2900	70
040-356/A	SD3500 + Brass Flag	1.1	3500	70

* Note: Detailed drawings available on request

3.6Kv Outdoor Immersed Bushings



PART NUMBER	DESCRIPTION	Kv RATING	CURRENT RATING	TANK HOLE SIZE
040-207	SE250	3.6	250	40
040-348	SE330	3.6	330	40
040-351	LE630	3.6	630	41
040-366	SE1250	3.6	1250	70
040-231	SE2500	3.6	2500	70
040-365	SE2900	3.6	2900	70

12Kv Outdoor Immersed Bushings

DL = Draw Lead
DL+T = Draw Lead + Tail

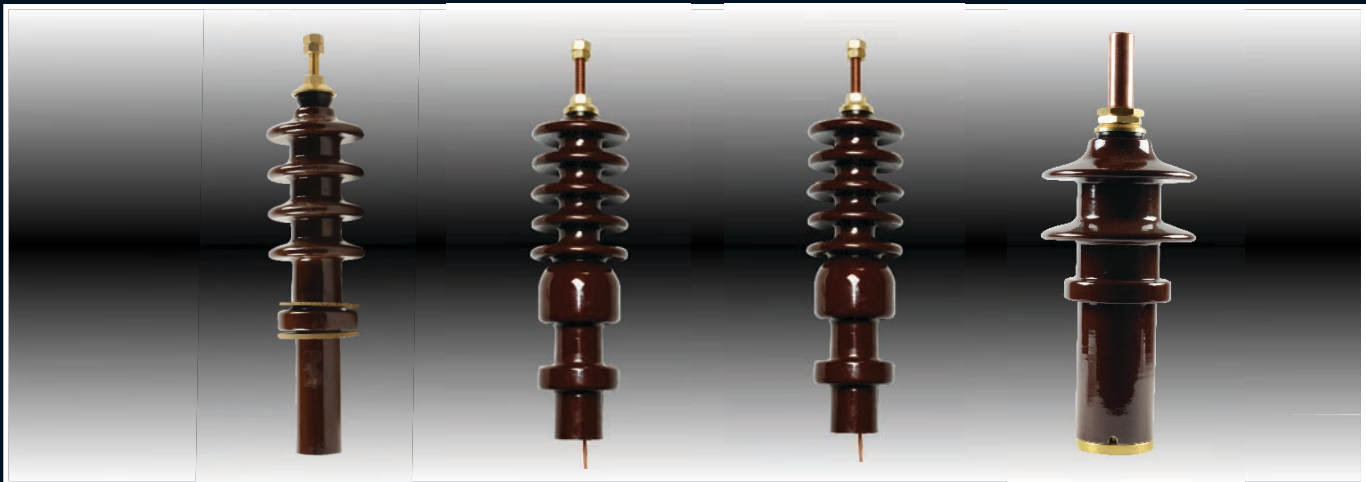

PART NUMBER	DESCRIPTION	Kv RATING	CURRENT RATING	TANK HOLE SIZE	CREEPAGE PER Kv (mm)
040-337	LF120	12	120	50	-
040-359	SFL250	12	250	55	31
040-352/R	SFLF250 DL	12	30	50	31
040-352/E	SFLF250 DL + T	12	30	50	31
040-354	SFLF250 Solid	12	250	50	31
040-358	LF630	12	630	60	25
040-357	LF1250	12	1250	75	25
040-232	LF2500 Long	12	2500	117	31
040-458	LF2900 Long	12	2900	117	31

* Note: Detailed drawings available on request

Enclosures

Hinges

Locks

Handles

Accessories

Rotary Operating
Handles

Insulators

Transformer
Equipment

Index

24Kv Outdoor Immersed Bushings

DL = Draw Lead
DL+T = Draw Lead + Tail

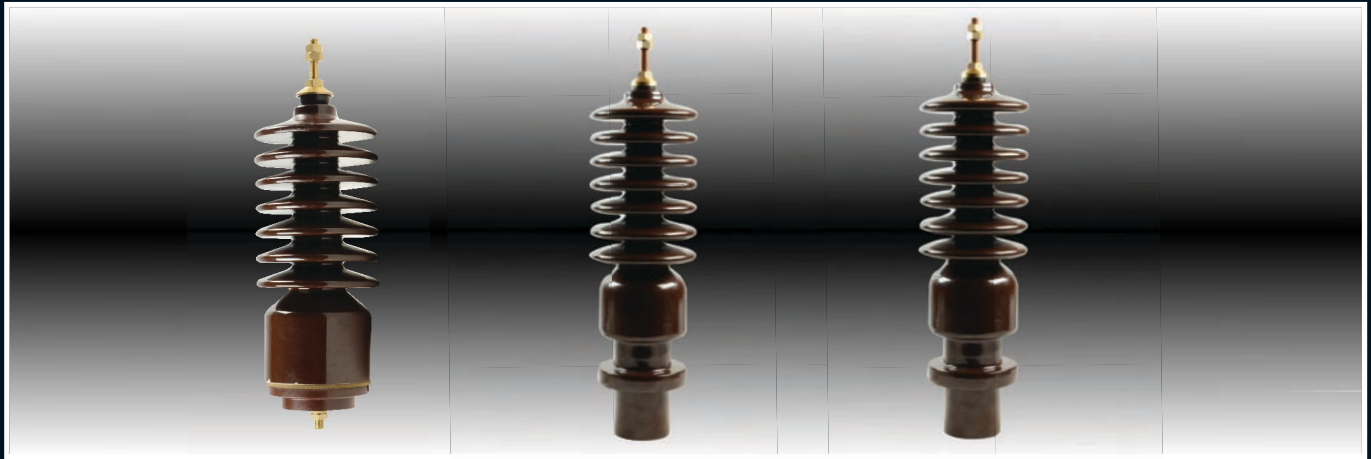

PART NUMBER	DESCRIPTION	Kv RATING	CURRENT RATING	TANK HOLE SIZE	CREEPAGE PER Kv (mm)
040-331	SG250	24	250	90	31
040-353	SGF250 DL	24	30	80	31
040-353/R	SGF250 DL + T	24	30	80	31
040-355	SGF250 Solid	24	250	80	31

36Kv Outdoor Immersed Bushings

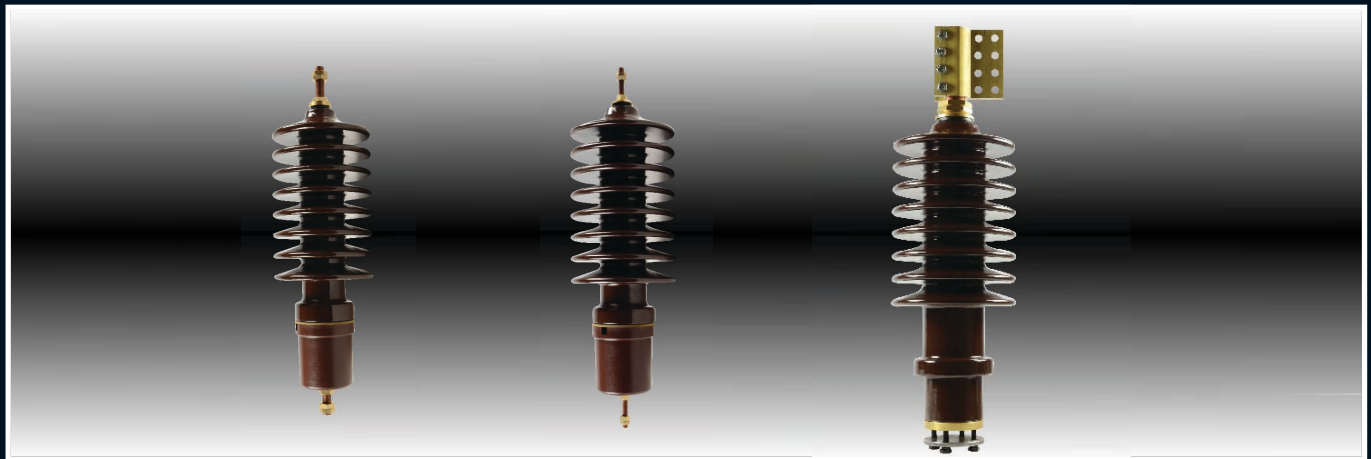

PART NUMBER	DESCRIPTION	Kv RATING	CURRENT RATING	TANK HOLE SIZE	CREEPAGE IN mm PER Kv
040-222	LH250 DL + T	36	30	90	31
040-221	LHC250	36	250	90	31
040-341	LH630	36	630	90	31
040-342	LHC630	36	630	90	31
040-544	LH1250 Long DL	36	630	117	31
040-541	LH1250 Long	36	1250	117	31
040-545	LH1250 Long SR	36	1250	117	31
040-546	LH2500 Long DL	36	630	117	31
040-540	LH2500 Long	36	2500	117	31
040-547	LH2500 Long SR	36	2500	117	31
040-362	LJ250	48	250	90	31

* **Note: Detailed drawings available on request**

Air- to-air Type

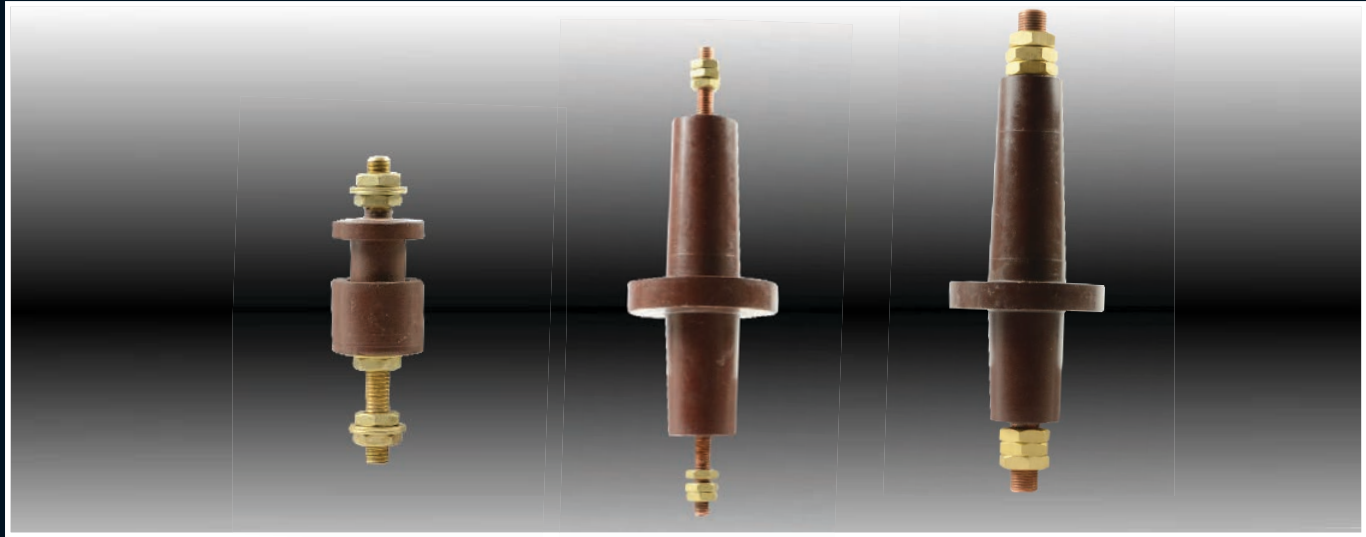

PART NUMBER	DESCRIPTION	Kv RATING (Um)	CURRENT RATING	TANK HOLE SIZE	PF - 60 SEC	STEM DIAMETER
070-392	FB10 Flame Proof	1.1	80	21	7.5Kv	M10
040-015	AA-062/250	7.2	250	50	18Kv	M12
040-019	AA-062-630	7.2	630	50	18Kv	M20
040-016	AA-112/250	12	250	50	30Kv	M12
040-017	AA-112/630	12	630	50	30Kv	M20
040-014	AA-113/250	12	250	50	30Kv	M12
040-020	AA-113/630	12	630	50	30Kv	M20

* Note: Detailed drawings available on request

Cable Box Type



PART NUMBER	DESCRIPTION	Kv RATING (Um)	CURRENT RATING	TANK HOLE SIZE	BIL	STEM DIAMETER
040-208	SM250	12Kv *	250	50	N/A	M12
040-005	IM250	12Kv	250	50	N/A	M12
040-032	CF1	22Kv	630	72	N/A	OD=20 , Tapped M12

* 7.2Kv Outdoor Rating * Note: Detailed drawings available on request

Enclosures

Hinges

Locks

Handles

Accessories

Rotary Operating Handles

Insulators

Transformer Equipment

Index

DIN Bushing Range



Note:
Bushings are manufactured to DIN 42530, 42539, 42531, 42532, 42533, 42534

PART NUMBER	DESCRIPTION	Kv RATING	I RATING	TANK HOLE SIZE	BIL	PF DRY	PF WET	CREEPAGE	STEM CONNECT
DT 1/250	DIN 42530 1/250	1	250	-	-	-	-	60	M12
DT 1/630	DIN 42530 1/630	1	630	45	-	-	-	75	M20
DT 1/1000	DIN 42530 1/1000	1	1000	56	-	-	-	75	M30
DT 1/2000	DIN 42530 1/2000	1	2000	70	-	-	-	75	M42
DT 1/3150	DIN 42530 1/3150	1	3150	90	-	-	-	75	M48
DT 3/250	DIN 42539 3/250	3	250	39	40	14	10	120	M12
DT 3/630	DIN 42539 3/630	3	630	45	40	14	10	120	M20
DT 3/1000	DIN 42539 3/1000	3	1000	56	40	14	10	125	M30
DT 3/2000	DIN 42539 3/2000	3	2000	70	40	14	10	125	M42
DT 3/3150	DIN 42539 3/3150	3	3150	90	40	14	10	125	M48
DT 3/4500	DIN 42539 3/4500	3	4500	119	40	14	10	130	M55
DT 3/6500	DIN 42539 3/6500	3	6500	119	40	14	10	130	M75
10NF250	DIN 42531 10NF250	12	250	78	75	28	-	305	M12
10NF630	DIN 42532 10NF630	12	630	90	75	28	-	305	M20
10NF1000	DIN 42533 10NF1000	12	1000	110	75	28	-	295	M30
10NF2000	DIN 42533 10NF2000	12	2000	135	75	28	-	295	M42
10NF3150	DIN 42533 10NF3150	12	3150	135	75	28	-	295	M48
20NF250	DIN 42531 20NF250	24	250	78	125	50	-	450	M12
20NF630	DIN 42532 20NF630	24	630	90	125	50	-	440	M20
20NF1000	DIN 42533 20NF1000	24	1000	110	125	50	-	445	M30
20NF2000	DIN 42533 20NF2000	24	2000	135	125	50	-	445	M42
20NF3150	DIN 42533 20NF3150	24	3150	135	125	50	-	445	M48
30NF250	DIN 42531 30NF250	36	250	78	170	70	-	607	M12
30NF630	DIN 42532 30NF630	36	630	90	170	70	-	662	M20
30NF1000	DIN 42533 30NF1000	36	1000	110	170	70	-	635	M30
30NF2000	DIN 42533 30NF2000	36	2000	135	170	70	-	635	M42
30NF3150	DIN 42533 30NF3150	36	3150	135	170	70	-	635	M48
52/1000	DIN 42534 52KV 1000	52	1000	135	250	95	-	950	M30
52/2000	DIN 42534 52KV 2000	52	2000	135	250	95	-	950	M42
52/3150	DIN 42534 52KV 3150	52	3150	135	250	95	-	950	M48

EN Bushing Range



Note:
Bushings are manufactured to EN50180 and EN50386

PART NUMBER	DESCRIPTION	Kv RATING	CURRENT RATING	TANK HOLE SIZE	BIL	PF DRY	PF WET	CREEPAGE	STEM CONNECT
EN 1/250	EN 50386 1/250	1.1	250	28	20	10	10	55	M12 / M12
EN 1/250 P	EN 50386 1/250 P	1.1	250	28	20	10	10	55	M12 / 23x23x5
EN 1/630	EN 50386 1/630	1.1	630	45	20	10	10	55	M20 / M20
EN 1/630 P	EN 50386 1/630 P	1.1	630	45	20	10	10	55	M20 / 32x32x9
EN 1/1250	EN 50386 1/1250	1.1	1250	56	20	10	10	75	M30 / 70 ø x 10
EN 1/1000 P	EN 50386 1/1000 P	1.1	1000	56	20	10	10	75	M30 / 57x57x12
EN 1/1250 P	EN 50386 1/1250 P	1.1	1250	56	20	10	10	75	M30 / 57x57x12
EN 1/2000	EN 50386 1/2000	1.1	2000	70	20	10	10	75	M42 / 100x100x15
EN 1/2000 P	EN 50386 1/2000 P	1.1	2000	70	20	10	10	75	M42 / 80x30x15
EN 1/3150	EN 50386 1/3150	1.1	3150	90	20	10	10	75	M48 / 110x110x15
EN 1/3150 P	EN 50386 1/3150 P	1.1	3150	90	20	10	10	75	M48 / 120x30x15
EN 1/4000	EN 50386 1/4000	1.1	4000	118	20	10	10	85	M55 / 160x160x24
EN 12/250 P2	EN 50180 12/250 P2	12	250	80	75	-	28	240	M12/M12
EN 12/250 P4	EN 50180 12/250 P4	12	250	80	75	-	28	372	M12/M12
EN 12/630 P2	EN 50180 12/630 P2	12	630	90	75	-	28	240	M20/M20
EN 12/630 P4	EN 50180 12/630 P4	12	630	90	75	-	28	372	M20/M20
EN 12/1250 P4	EN 50180 12/1250 P4	12	1250	110	75	-	28	372	M30/M30
EN 12/2000 P4	EN 50180 12/2000 P4	12	2000	135	75	-	28	372	M42/M42
EN 12/3150 P4	EN 50180 12/3150 P4	12	3150	135	75	-	28	372	M48/M48
EN 24/250 P2	EN 50180 24/250 P2	24	250	80	125	-	50	480	M12/M12
EN 24/250 P4	EN 50180 24/250 P4	24	250	80	125	-	50	744	M12/M12
EN 24/630 P2	EN 50180 24/630 P2	24	630	90	125	-	50	480	M20/M20
EN 24/630 P4	EN 50180 24/630 P4	24	630	90	125	-	50	744	M20/M20
EN 24/1250 P4	EN 50180 24/1250 P4	24	1250	110	125	-	50	744	M30/M30
EN 24/2000 P4	EN 50180 24/2000 P4	24	2000	135	125	-	50	744	M42/M42
EN 24/3150 P4	EN 50180 24/3150 P4	24	3150	135	125	-	50	744	M48/M48
EN 36/250 P2	EN 50180 36/250 P2	36	250	80	150	-	70	720	M12/M12
EN 36/250 P4	EN 50180 36/250 P4	36	250	80	150	-	70	1116	M12/M12
EN 36/630 P2	EN 50180 36/630 P2	36	630	90	150	-	70	720	M20/M20
EN 36/630 P4	EN 50180 36/630 P4	36	630	90	150	-	70	1116	M20/M20
EN 36/1250 P4	EN 50180 36/1250 P4	36	1250	110	150	-	70	1116	M30/M30
EN 36/2000 P4	EN 50180 36/2000 P4	36	2000	135	150	-	70	1116	M42/M42
EN 36/3150 P4	EN 50180 36/3150 P4	36	3150	135	150	-	70	1116	M48/M48

Enclosures

Hinges

Locks

Handles

Accessories

Rotary Operating
Handles

Insulators

Transformer
Equipment

Index

AU LV Bushing Range

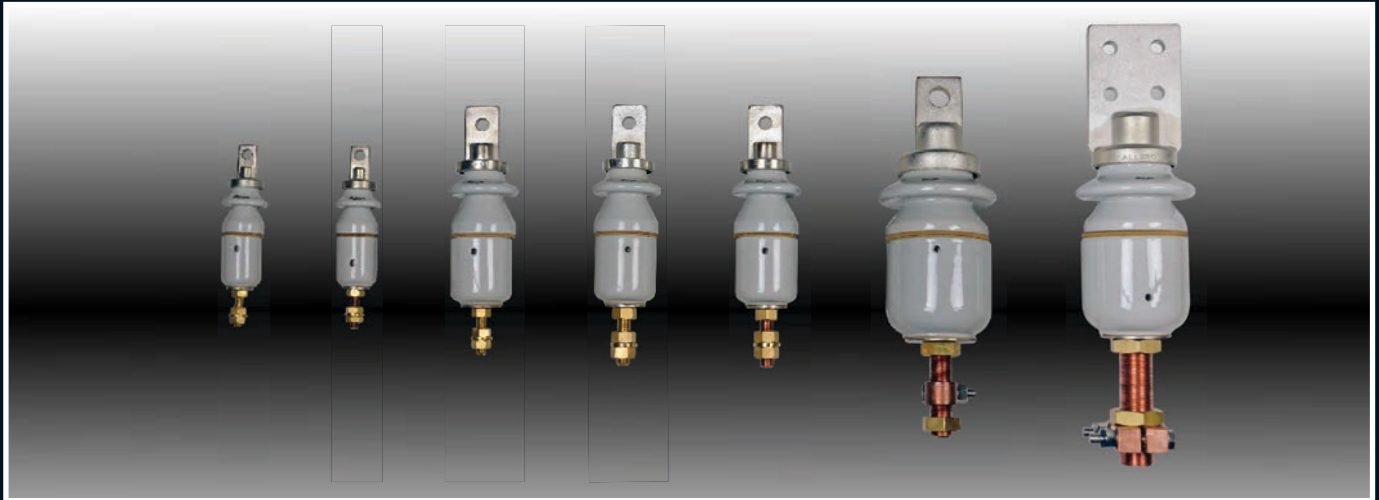

PART NUMBER	DESCRIPTION	Kv RATING	CURRENT RATING	TANK HOLE SIZE	BIL	PF	CREEPAGE
040-369/X	AU 0K6-120 1H14CU Bushing	600V	120A	29	10Kv	4Kv	>70
040-369/XT1	AU 0K6-120 2H14CU Bushing	600V	120A	29	10Kv	4Kv	>70
040-369/XA1	AU 0K6-120 1H11BR Bushing	600V	80A	29	10Kv	4Kv	>70
040-369/XA2	AU 0K6-120 1H11CU Bushing	600V	120A	29	10Kv	4Kv	>70
040-370/X	AU 3K6-200 1H14 Bushing	3.6Kv	200A	48	40Kv	16Kv	>105
040-370/XA1	AU 3K6-200 1H11 Bushing (A)	3.6Kv	200A	48	40Kv	16Kv	>105
040-371/X	AU 3K6-500 1H14 Bushing	3.6Kv	500A	48	40Kv	16Kv	>105
040-371/XA1	AU 3K6-500 2H14 Bushing (A)	3.6Kv	500A	48	40Kv	16Kv	>105
040-387/XE	AU 3K6-800 1H14 Bushing (E)	3.6Kv	800A	79	40Kv	16Kv	>115
040-375/X	AU 3K6-300 Bushing	3.6Kv	300A	48	40Kv	16Kv	>105
040-376/XW	AU 3K6-1000 Bushing S1H14 Bushing (W)	3.6Kv	1000A	72	40Kv	16Kv	>105
040-376/X	AU 3K6-1050 1H22 Bushing	3.6Kv	1050A	79	40Kv	16Kv	>115
040-376/XE	AU 3K6-1050 1H14 Bushing	3.6Kv	1050A	79	40Kv	16Kv	>115
040-376/XE2	AU 3K6-1050 2H14 Bushing (E)	3.6Kv	1050A	79	40Kv	16Kv	>115
040-376/XA2	AU 3K6-1050 1H18 Bushing (A)	3.6Kv	1050A	79	40Kv	16Kv	>115
040-379/XW	AU 3K6-1400 1H14 Bushing (W)	3.6Kv	1400A	79	40Kv	16Kv	>115
040-380/XW	AU 3K6-1400 2H14 Bushing (W)	3.6Kv	1400A	79	40Kv	16Kv	>115
040-381/XW	AU 3K6-1400 2H14 Bushing (W-SP)	3.6Kv	1400A	79	40Kv	16Kv	>115
040-381/XE	AU 3K6-1400 2H14 Bushing (E)	3.6Kv	1400A	79	40Kv	16Kv	>115
040-382/XW	AU 3K6-1400 1H18 Bushing (W)	3.6Kv	1400A	79	40Kv	16Kv	>115
040-383/XW	AU 3K6-1400 2H18 Bushing (W)	3.6Kv	1400A	79	40Kv	16Kv	>115
040-377/X	AU 3K6-2000 4H14 Bushing	3.6Kv	2000A	79	40Kv	16Kv	>115
040-377/XE	AU 3K6-2000 4H14 Bushing (E)	3.6Kv	2000A	79	40Kv	16Kv	>115
040-384/XW	AU 3K6-2700 2H22 Bushing (W)	3.6Kv	2700A	92	40Kv	16Kv	>120
040-388/XE	AU 3K6-3150 2H22 Bushing (E)	3.6Kv	3150A	92	40Kv	16Kv	>120

AU HV Bushing Range

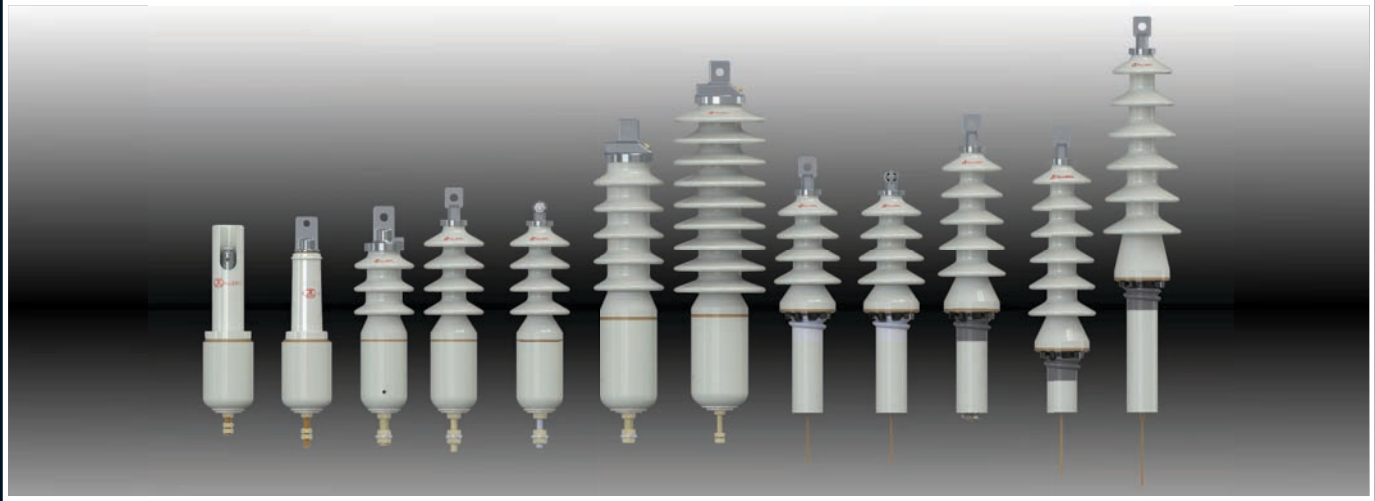

PART NUMBER	DESCRIPTION	Kv RATING	CURRENT RATING	TANK HOLE SIZE	BIL	PF	CREEPAGE
040-372/X	AU 12K-30 Bushing	12Kv	30A	71	75Kv	30Kv	>410
040-372/XE	AU 12K-30 CF Bushing (E)	12Kv	30A	71	75Kv	30Kv	>410
040-372/XW	AU 12K-30 Bushing (W)	12Kv	30A	71	75Kv	30Kv	>410
040-385/XW	AU 12K-300A 3S Bushing (W)	12Kv	300A	60	75Kv	30Kv	>285
040-386/XE	AU 12K-30A 4S-PF Bushing (E)	12Kv	30A	60	75Kv	30Kv	>345
040-389/XE	AU 12K-30A 4S-CF Bushing (E)	12Kv	30A	60	75Kv	30Kv	>345
040-394/XE	AU 12K-200 4S Bushing (E)	12Kv	200A	60	75Kv	30Kv	>345
040-390/XW	AU 12K-300A 4S Bushing (W)	12Kv	300A	60	75Kv	30Kv	>345
040-391/XE	AU 12K-160 CB Bushing (E)	12Kv	160A	60	75Kv	30Kv	>160
040-393/XE	AU 11K-160 Shrouded Bushing (E)	12Kv	160A	60	75Kv	30Kv	>160
040-373/X	AU 24K-30 Bushing	24Kv	30A	71	125Kv	50Kv	>530
040-373/XE	AU 24K-30 CF Bushing (E)	24Kv	30A	71	125Kv	50Kv	>530
040-373/XW	AU 24K-30 Bushing (W)	24Kv	30A	71	125Kv	50Kv	>530
040-399/XW	AU 24K-300 5S Bushing (W)	24Kv	300A	80	125Kv	50Kv	>480
040-374/X	AU 24K-30 XS Bushing	24Kv	30A	71	125Kv	50Kv	>640
040-374/XW	AU 24K-30 XS Bushing (W)	24Kv	30A	71	125Kv	50Kv	>640
040-378/X	AU 36K-30 Bushing	36Kv	30A	71	170Kv	70Kv	>720
040-368/X	AU 44KV-120 9S Bushing	44Kv	120A	80	170Kv	77Kv	>1067

Enclosures

Hinges

Locks

Handles

Accessories

Rotary Operating
Handles

Insulators

Transformer
Equipment

Index

Enclosures

Hinges

Locks

Handles

Accessories

Rotary Operating Handles

Insulators

Transformer Equipment

Index

Offset Bushings

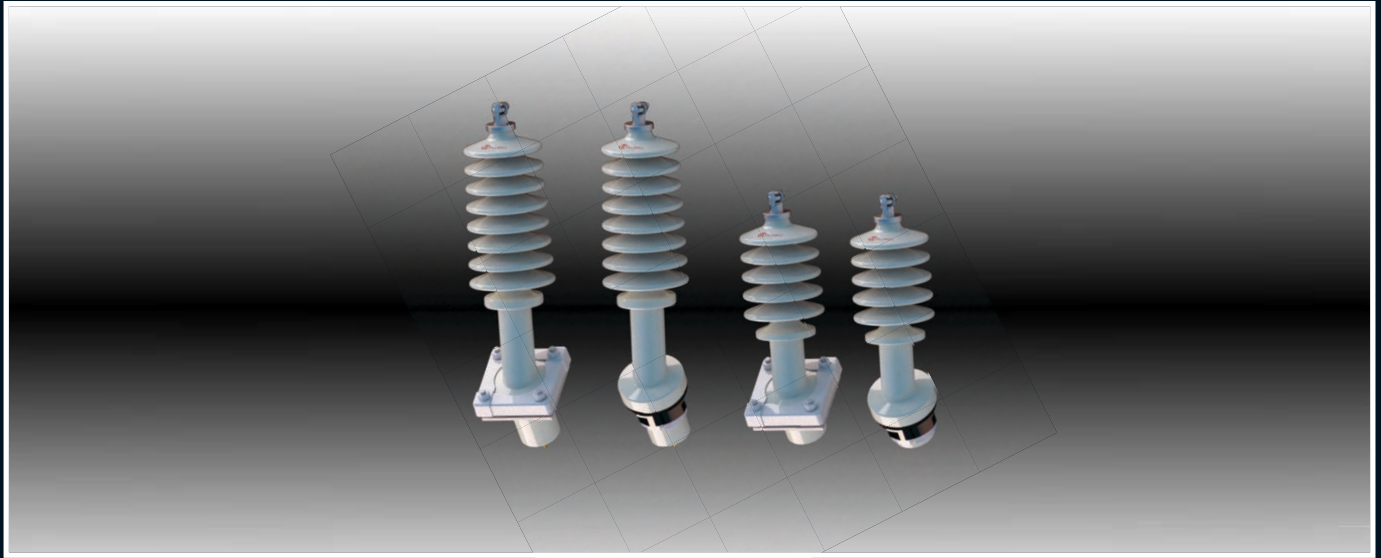

PART NUMBER	DESCRIPTION	Kv RATING	CURRENT RATING	TANK HOLE SIZE	BIL	PF	CREEPAGE
040-395/X	AU 12K-30 Offset Bushing	12Kv	30A	70	75Kv	30Kv	>706
040-396/X	AU 12K-30 Offset Bushing	12Kv	30A	70	75Kv	30Kv	>660
040-397/X	AU 36K-30 Offset Bushing	24Kv	30A	70	125Kv	50Kv	>1036
040-398/X	AU 36K-30 Offset Bushing	24Kv	30A	70	125Kv	50Kv	>990

Wildlife Guards

The Wildlife Guards are optimized for wildlife protection on over-head distribution systems rated 25Kv and less. These guards are designed to mount securely between the first and second shed (nearest the high voltage terminal) on primary bushings and arresters.



PART NUMBER	DESCRIPTION
WLG-140	Wildlife Guard Shed Mount - 136mm
WLG-230	Wildlife Guard Shed Mount - 116mm

RTS = Rotary Tap Switch
LTS = Linear Tap Switch
MB = Moulded Bracket
BC = Butterfly Contact
A = LEFT HAND
B = RIGHT HAND

Rotary Tap Switches

Contact Arrangement Types

All Rotary Tap - Switches are available with two types of moving contacts as indicated below:

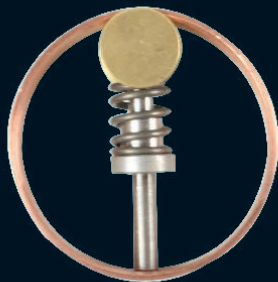

Standard Contact Arrangement



Butterfly Contact Arrangement

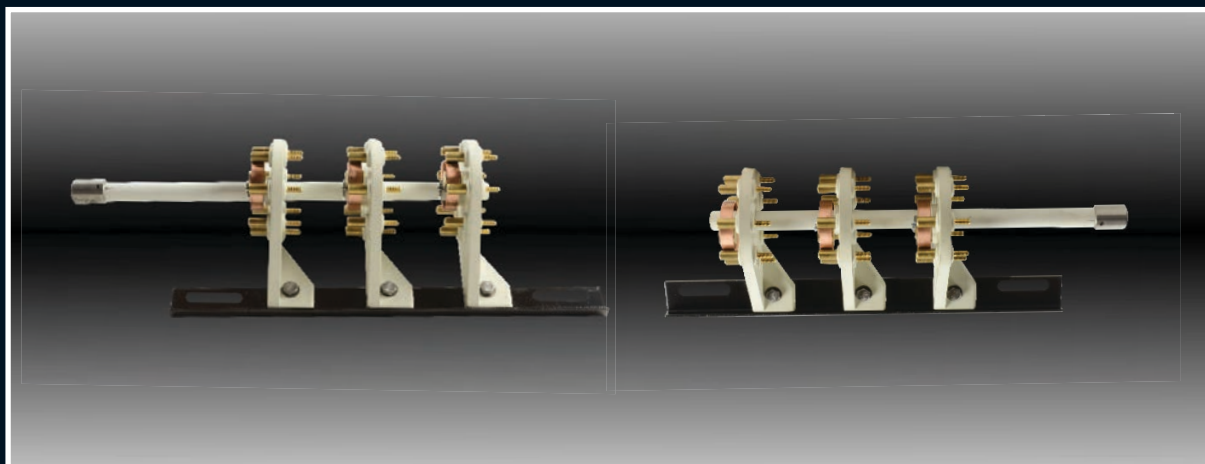

PART NUMBER	DESCRIPTION	Kv	CURRENT	PHASE	TYPE	BRACKET	CONTACT
040-522	RTS 22 Kv 100A 1Ph - Type A	22	100	1	A	Steel	Std
040-523	RTS 22 Kv 100A 1Ph - Type B	22	100	1	B	Steel	Std
040-508 BC	RTS 22Kv 100A 3Ph - Type A / 90° / BC	22	100	3	A	Steel	Butterfly
040-505	RTS 22Kv 100A 3Ph - Type A / MB	22	100	3	A	Moulded	Std
040-528	RTS 22Kv 100A 3Ph - Type A	22	100	3	A	Steel	Std
040-530	RTS 22Kv 100A 3Ph - Type AB	22	100	3	AB	Steel	Std
040-530 BC	RTS 22Kv 100A 3Ph - Type AB / BC	22	100	3	AB	Steel	Butterfly
040-506 BC	RTS 22Kv 100A 3Ph - Type B / 90° / BC	22	100	3	B	Steel	Butterfly
040-501	RTS 22Kv 100A 3Ph - Type B / MB	22	100	3	B	Moulded	Std
040-527	RTS 22Kv 100A 3Ph - Type B	22	100	3	B	Steel	Std

Enclosures

Hinges

Locks

Handles

Accessories

Rotary Operating
Handles

Insulators

Transformer
Equipment

Index

Enclosures

Hinges

Locks

Handles

Accessories

Rotary Operating
Handles

Insulators

Transformer
Equipment

Index

RTS = Rotary Tap Switch
LTS = Linear Tap Switch
MB = Moulded Bracket
BC = Butterfly Contact
A = LEFT HAND
B = RIGHT HAND

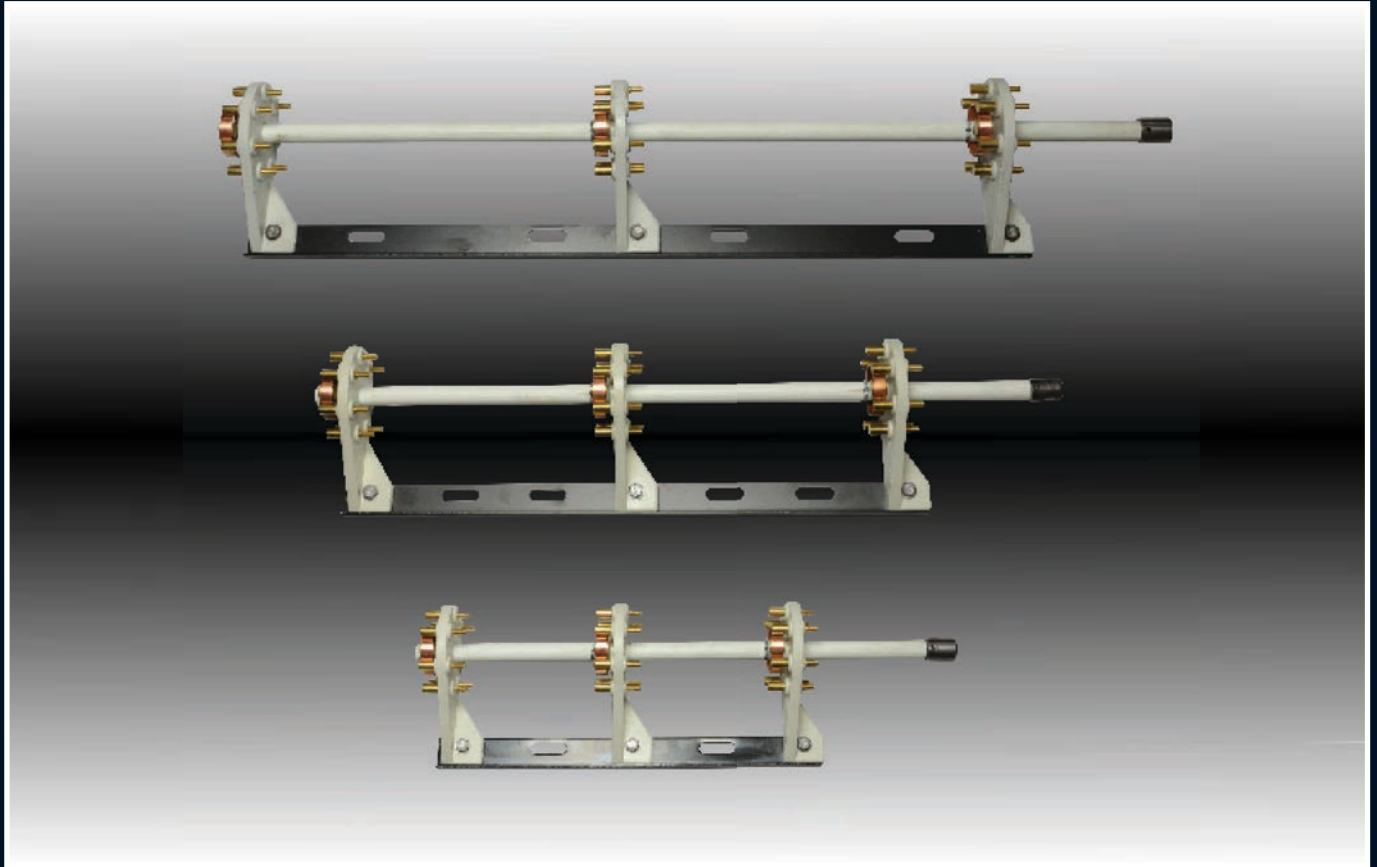

PART NUMBER	DESCRIPTION	Kv	CURRENT	PHASE	TYPE	BRACKET	CONTACT
040-534	RTS 22Kv 100A 3Ph (180 CNT) Type AB	22	100	3	AB	Steel	Std
040-533	RTS 22Kv 100A 3Ph (270 CNT) Type AB	22	100	3	AB	Steel	Std
040-532	RTS 22Kv 100A 3Ph (360 CNT) Type AB	22	100	3	AB	Steel	Std
040-521	RTS 22Kv 100A 3Ph (180 CNT) Type A	22	100	3	A	Steel	Std
040-518	RTS 22Kv 100A 3Ph (180 CNT) Type B	22	100	3	B	Steel	Std
040-520	RTS 22Kv 100A 3Ph (270 CNT) Type A	22	100	3	A	Steel	Std
040-517	RTS 22Kv 100A 3Ph (270 CNT) Type B	22	100	3	B	Steel	Std
040-519	RTS 22Kv 100A 3Ph (360 CNT) Type A	22	100	3	A	Steel	Std
040-516	RTS 22Kv 100A 3Ph (360 CNT) Type B	22	100	3	B	Steel	Std

RTS = Rotary Tap Switch
LTS = Linear Tap Switch
MB = Moulded Bracket
BC = Butterfly Contact
A = LEFT HAND
B = RIGHT HAND

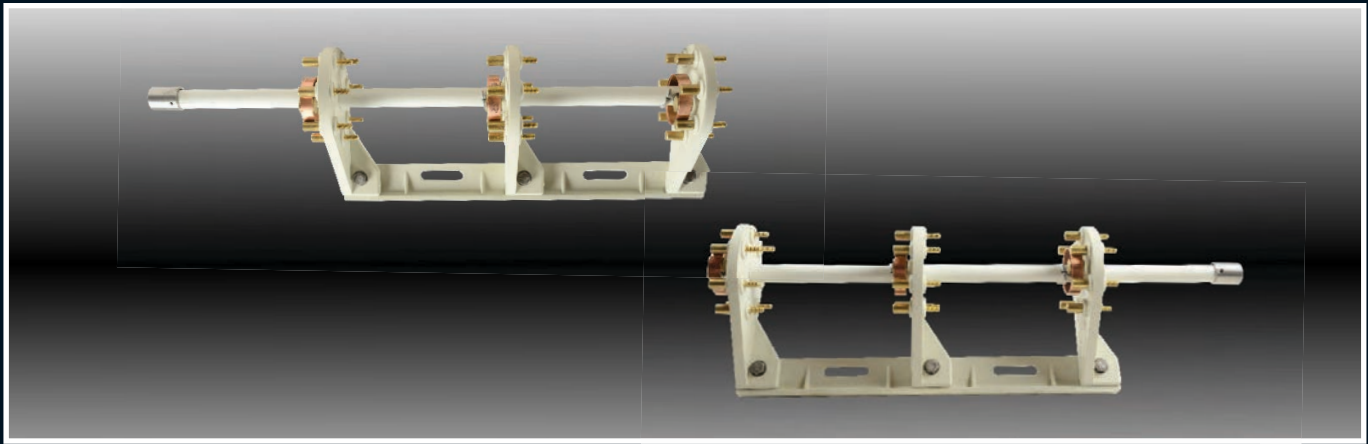

PART NUMBER	DESCRIPTION	Kv	CURRENT	PHASE	TYPE	BRACKET	CONTACT
040-512	RTS 33Kv 100A 3Ph - Type A / MB	33	100	3	A	Moulded	Std
040-529 BC	RTS 33Kv 100A 3Ph - Type AB / BC	33	100	3	AB	Moulded	Butterfly
040-529	RTS 33Kv 100A 3Ph - Type AB / MB	33	100	3	AB	Moulded	Std
040-500	RTS 33Kv 100A 3Ph - Type B / MB	33	100	3	B	Moulded	Std

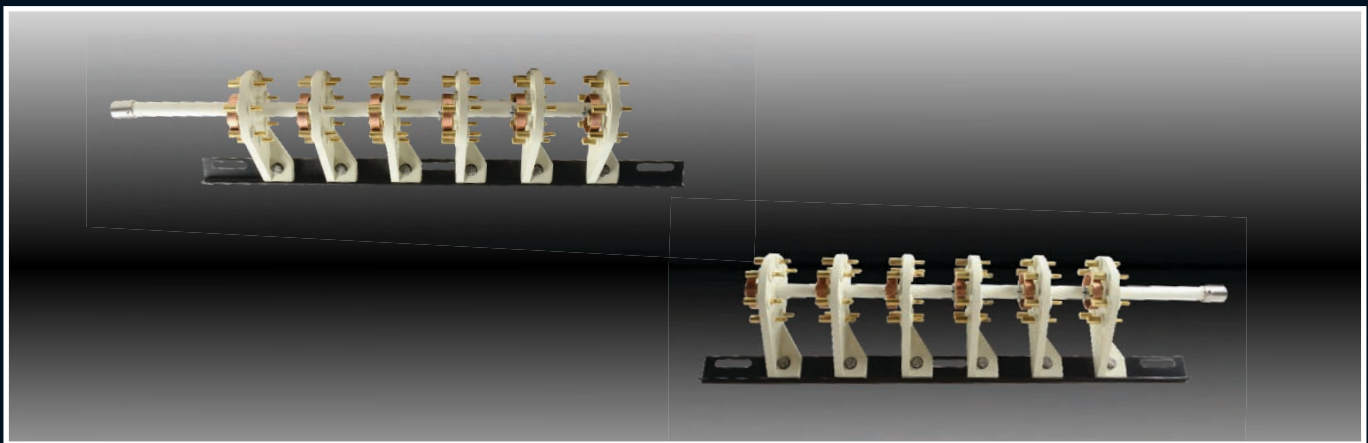

PART NUMBER	DESCRIPTION	Kv	CURRENT	PHASE	TYPE	BRACKET	CONTACT
040-513	RTS 22Kv 100A 6Ph - Type A	22	100	6	A	Steel	Std
040-531	RTS 22Kv 100A 6Ph - Type AB	22	100	6	AB	Steel	Std
040-502	RTS 22Kv 100A 6Ph - Type B	22	100	6	B	Steel	Std

Enclosures

Hinges

Locks

Handles

Accessories

Rotary Operating
Handles

Insulators

Transformer
Equipment

Index

Enclosures

RTS = Rotary Tap Switch
LTS = Linear Tap Switch
MB = Moulded Bracket
BC = Butterfly Contact
A = LEFT HAND
B = RIGHT HAND

Hinges

Locks

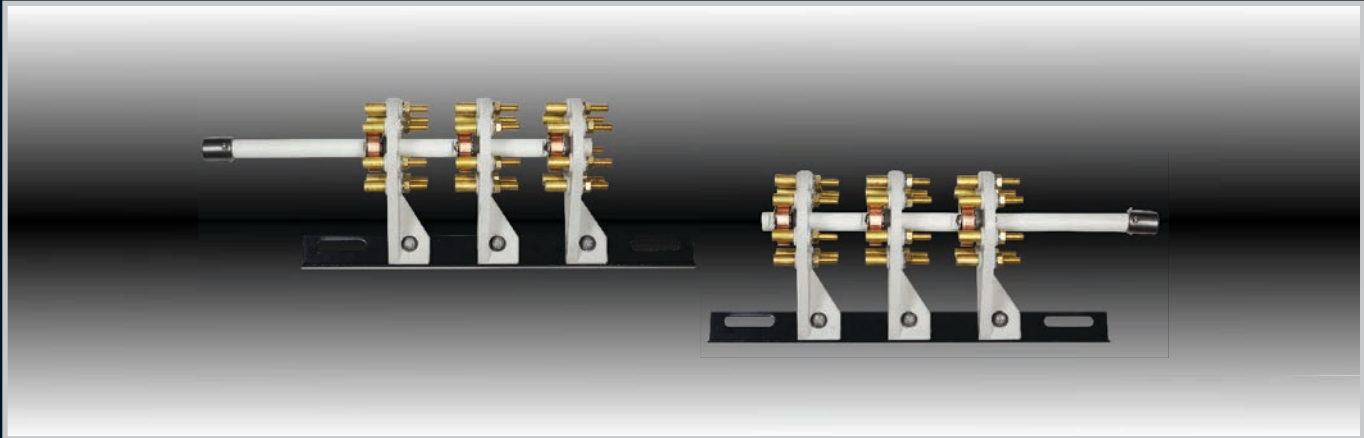

Handles

PART NUMBER	DESCRIPTION	Kv	CURRENT	PHASE	TYPE	BRACKET	CONTACT
040-509 BC	RTS 22Kv 150A 3Ph - Type A / 90° / BC	22	150	3	A	Steel	Butterfly
040-510 BC	RTS 22Kv 150A 3Ph - Type A / BC	22	150	3	A	Steel	Butterfly
040-511 BC	RTS 22Kv 150A 3Ph - Type B / 90° / BC	22	150	3	B	Steel	Butterfly
040-507 BC	RTS 22Kv 150A 3Ph - Type B / BC	22	150	3	B	Steel	Butterfly

Accessories

Rotary Operating Handles

Insulators

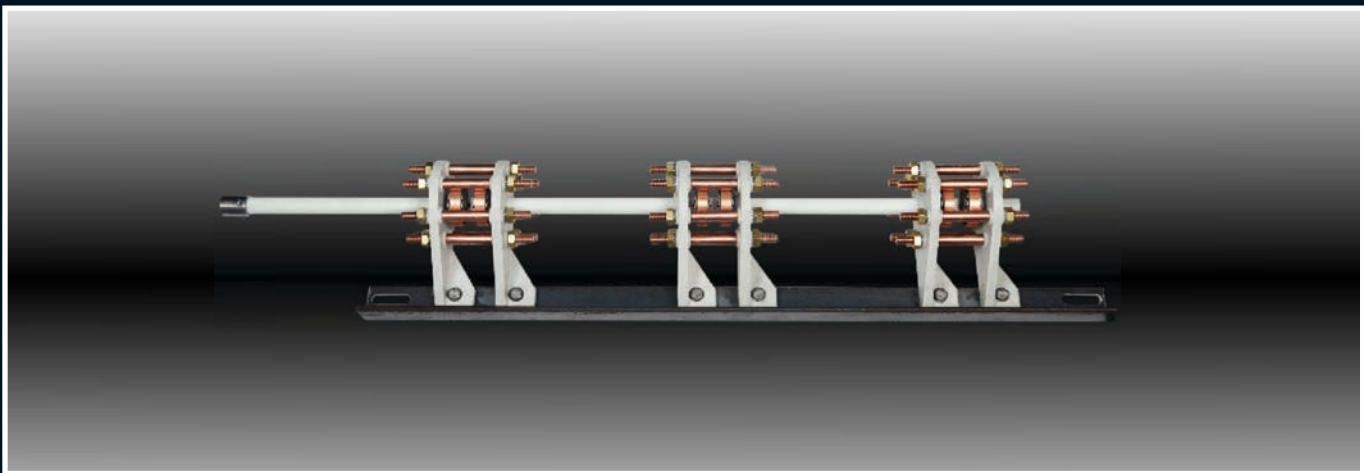

Transformer Equipment

PART NUMBER	DESCRIPTION	Kv	CURRENT	PHASE	TYPE	BRACKET	CONTACT
040-514 BC	RTS 22Kv 300A 3Ph - Type A / BC	22	300	3	A	Steel	Butterfly
040-538 BC	RTS 22Kv 300A 3Ph - Type AB / BC	22	300	3	AB	Steel	Butterfly
040-503 BC	RTS 22Kv 300A 3Ph - Type B / BC	22	300	3	B	Steel	Butterfly

Index

SC = Slide Contact
RTS = Rotary Tap Switch
LTS = Linear Tap Switch
MB = Moulded Bracket
BC = Butterfly Contact
A = LEFT HAND
B = RIGHT HAND

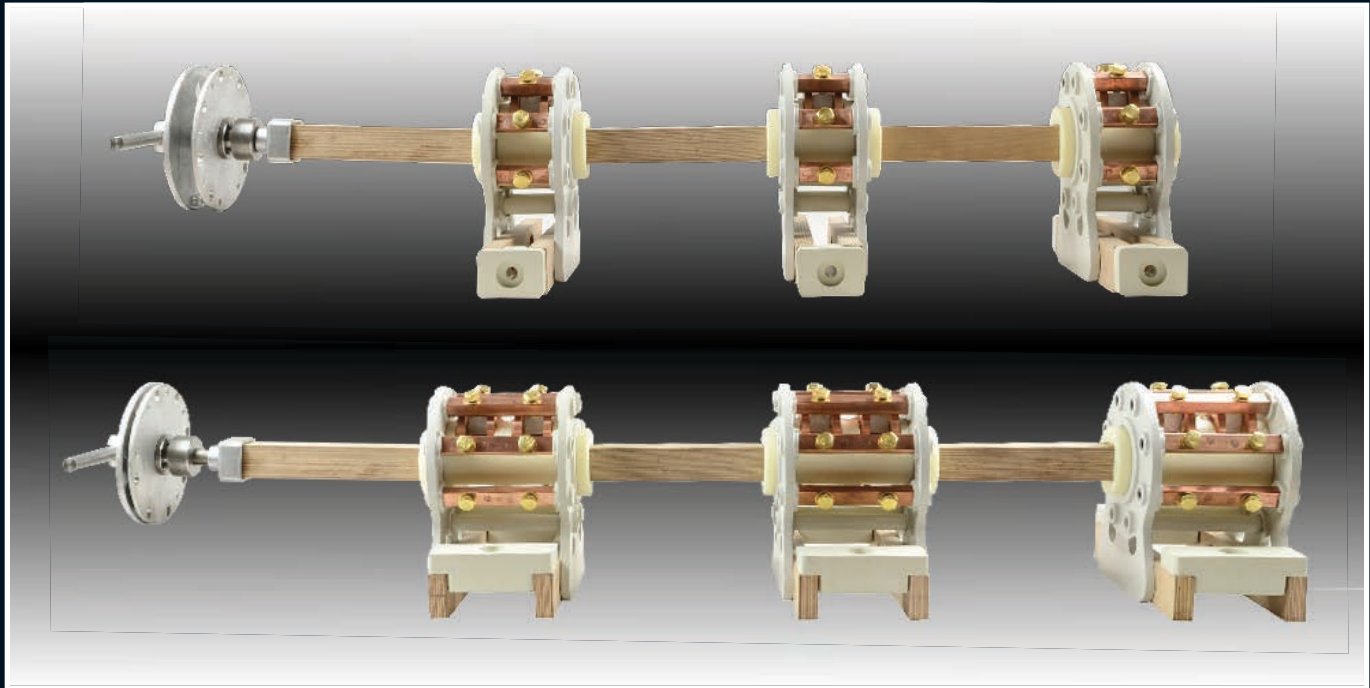

PART NUMBER	DESCRIPTION	Kv	CURRENT	PHASE	TYPE	BRACKET	CONTACT
040-543	RTS 88Kv 315A 3Ph - Type AB	88	315	3	AB	Permali	T - Type
040-542	RTS 88Kv 630A 3Ph - Type AB	88	630	3	AB	Permali	T - Type

Linear Tap Switches



PART NUMBER	DESCRIPTION	Kv	CURRENT	PHASE	TYPE	BRACKET	CONTACT
040-526	LTS 22Kv 30A 2Ph 5Pos	22	30	2	N/A	Nylon	Linear
040-525	LTS 22Kv 30A 3Ph 5Pos	22	30	3	N/A	Nylon	Linear

Enclosures

Hinges

Locks

Handles

Accessories

Rotary Operating
Handles

Insulators

Transformer
Equipment

Index

Enclosures

Hinges

Locks

Handles

Accessories

Rotary Operating Handles

Insulators

Transformer Equipment

Index

RTS = Rotary Tap Switch
LTS = Linear Tap Switch
MB = Moulded Bracket
BC = Butterfly Contact
A = LEFT HAND
B = RIGHT HAND

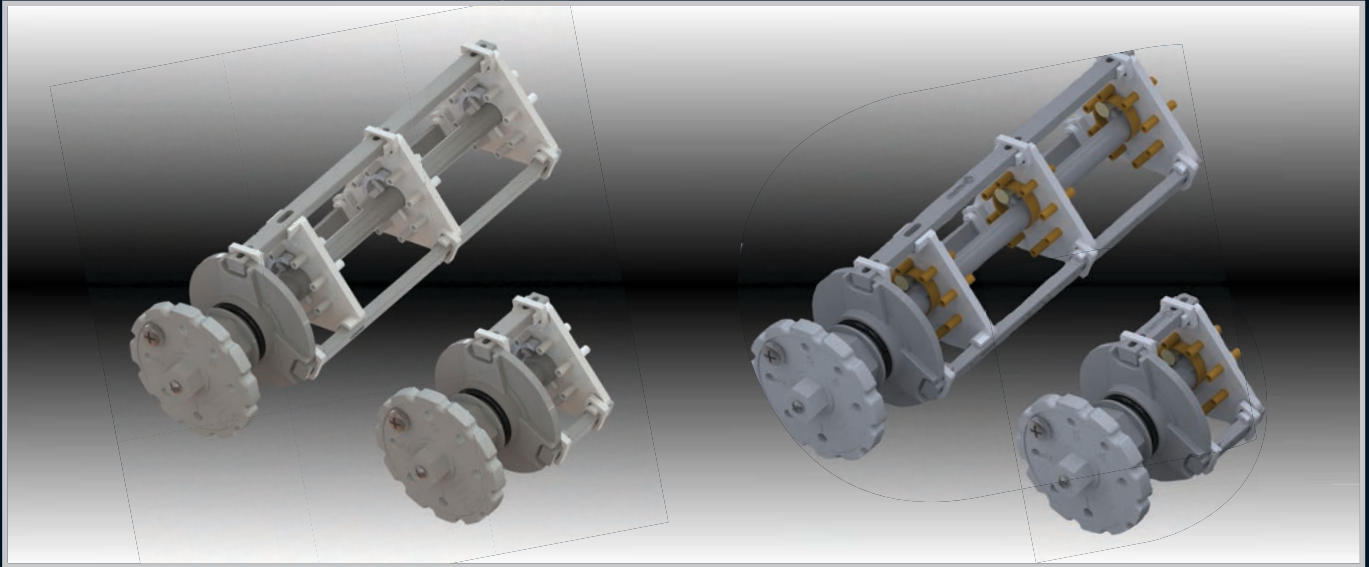

PART NUMBER	DESCRIPTION	Kv	CURRENT	PHASE	TYPE	BRACKET	CONTACT
040-580X	RTS 33Kv 60A 1PH 7 POS - SC	33	60A	1	N/A	N/A	Slide
040-581X	RTS 33Kv 60A 3PH 7 POS - SC	33	60A	3	N/A	N/A	Slide
040-585X	RTS 33Kv 60A 1PH 7POS - RC/DP	33	60A	1	N/A	N/A	Slide
040-586X	RTS 33Kv 60A 3PH 7POS - RC/DP	33	60A	3	N/A	N/A	Slide

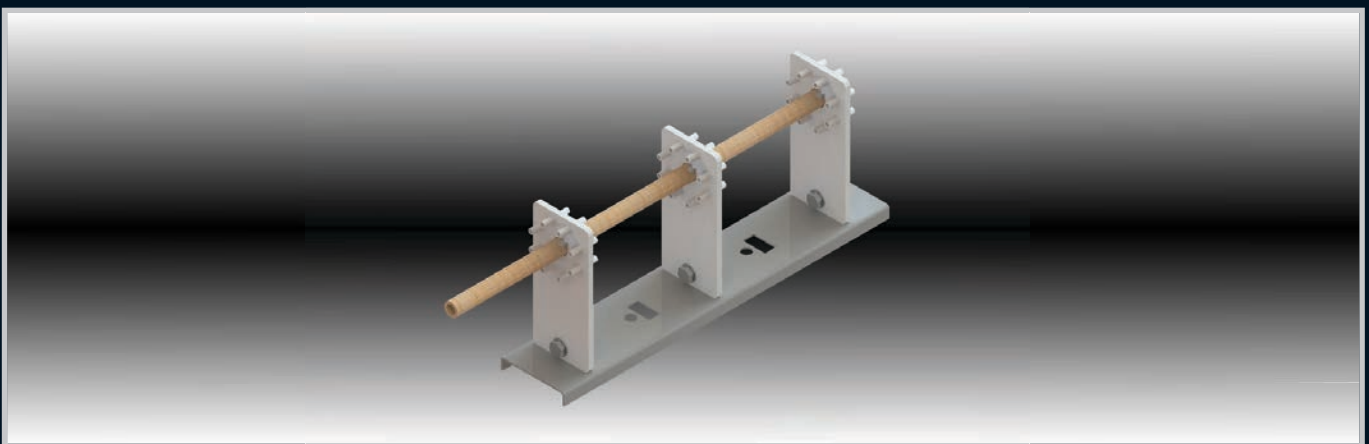

PART NUMBER	DESCRIPTION	Kv	CURRENT	PHASE	TYPE	CONTACT
040-582/X	RTS 33Kv 60A 3Ph 7 POS - SC/SP	33	60A	3	AB	Slide
040-583/X	RTS 6.6Kv 60A 3Ph 7 POS - SC/SP	6.6	60A	3	AB	Slide
040-584/X	RTS 33Kv 60A 1Ph 7 POS - SC/SP	33	60A	1	AB	Slide

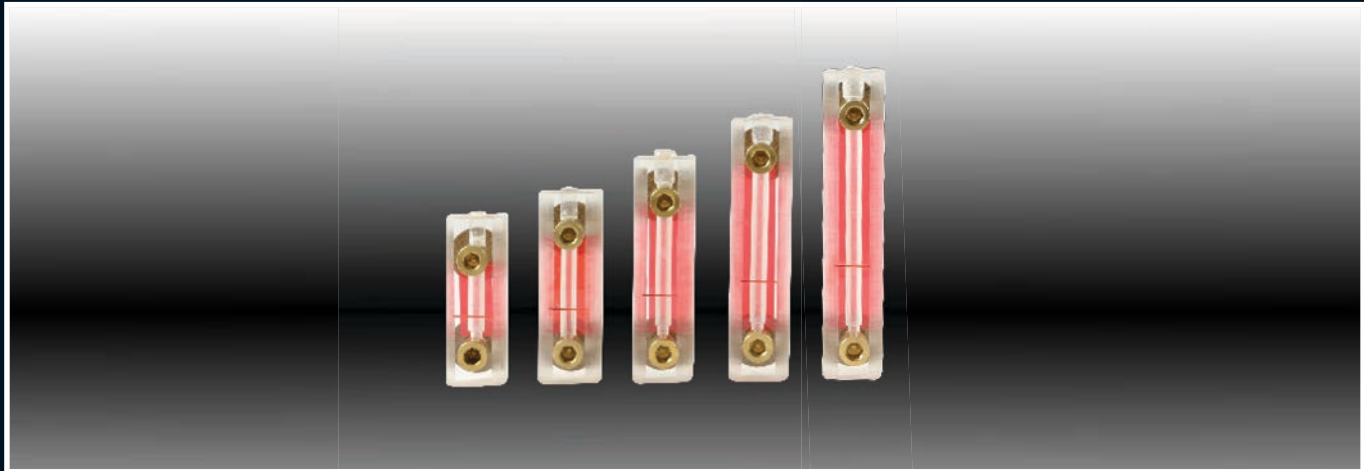

PART NUMBER	DESCRIPTION	BOLT CENTERS	TOTAL LENGHT	LINE HEIGHT
LOG-50	Oil Gauge 50	50	90	17
LOG-63	Oil Gauge 63	63	103	21
LOG-80	Oil Gauge 80	80	120	27
LOG-100	Oil Gauge 100	100	140	33
LOG-125	Oil Gauge 125	125	165	42
LOG-144	Oil Gauge 144	144	184	48
LOG-180	Oil Gauge 180	180	220	60
LOG-230	Oil Gauge 230	230	270	77
LOG-288	Oil Gauge 288	288	328	96
LOG-360	Oil Gauge 360	360	400	120

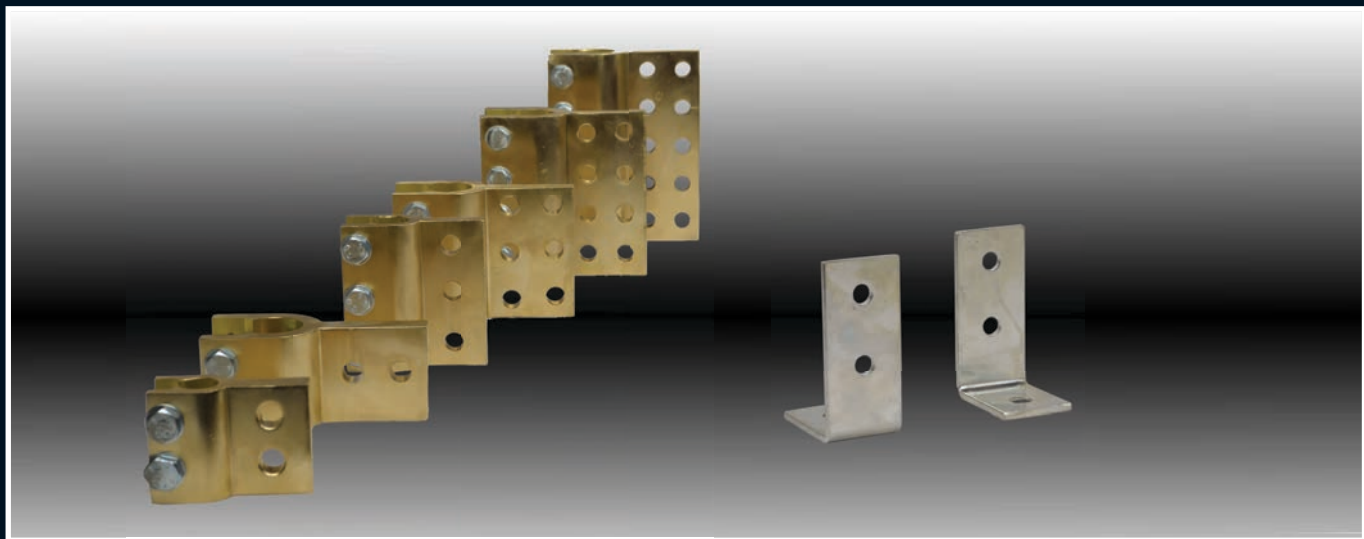

PART NUMBER	DESCRIPTION	TYPE	FLAG HEIGHT	HOLE SIZE
010-077	SAD250 Flag	Copper L Shape	110mm	13mm Diameter
010-078	SAD330 Flag	Copper L Shape	110mm	15mm Diameter
010-079	SB 500 Flag	Copper L Shape	110mm	19mm Diameter
010-080	SB 630 Flag	Copper L Shape	110mm	21mm Diameter
010-003	SC850 /1250 Flag	Brass "Y" Extrusion	60mm	21mm Diameter
010-088	SC1250 Flag	Brass "Y" Extrusion	60mm	38mm Diameter
010-098	SD1600 Flag	Brass "Y" Extrusion	100mm	27mm Diameter
010-004	SD2500 Flag	Brass "Y" Extrusion	100mm	38mm Diameter
010-151	SD2900 Flag	Brass "Y" Extrusion	135mm	38mm Diameter
010-076	SD3500 Flag	Brass "Y" Extrusion	172mm	38mm Diameter

Enclosures

Hinges

Locks

Handles

Accessories

Rotary Operating
Handles

Insulators

Transformer
Equipment

Index

Enclosures

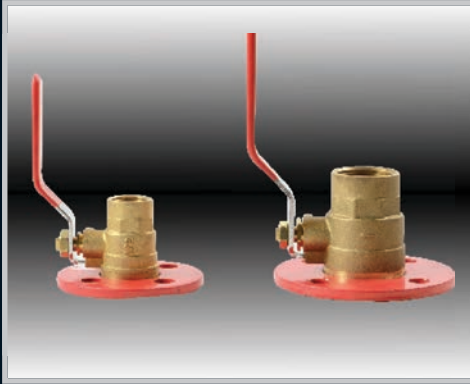

PART NUMBER	DESCRIPTION
021-402	0.5" Ball Valve Only (15mm)
021-403	0.5" Ball Valve Single Fixed Flange (15mm)
021-419	0.5" Ball Valve Single Rotating Flange (15mm)
021-409	0.5" Ball Valve Double Flange (15mm)
021-406	1" Ball Valve Only (25mm)
021-404	1" Ball Valve Single Fixed Flange (25mm)
021-420	1" Ball Valve Single Rotating Flange (25mm)
021-410	1" Ball Valve Double Flange (25mm)

Hinges

Locks

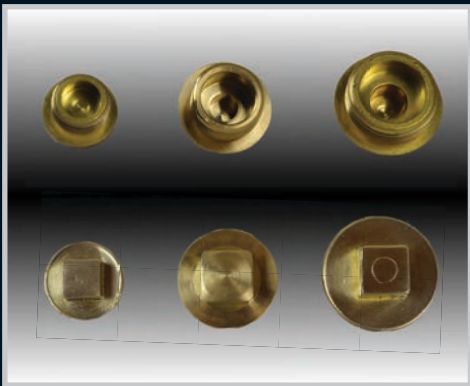

PART NUMBER	DESCRIPTION	THREAD
002-059	0.5" Brass Plug	0.5" BSP
002-136	0.75" Brass Plug	0.75" BSP
002-055	1" Brass Plug	1" BSP

Handles

Accessories



PART NUMBER	DESCRIPTION	ORI FACE Ø	H	L	NO. OF STUDS	STUD SIZE (mm)	STU PCD (mm)	STUD CTC (mm)
040-368	Radiator Valve 80x125	73mm	125	125	4	16	125	88
040-367	Radiator Valve 80x138	76mm	138	138	4	16	146	103

Rotary Operating
Handles

Insulators



PART NUMBER	DESCRIPTION	ORIFACE Ø (mm)	H (mm)	THREAD
002-057	20mm Weld on Boss	20	30	M12
002-058	25mm Weld on Boss	25	30	M12

Transformer
Equipment

Index



Silica Gel:
The breathers contain the latest EU & ESKOM specified grade of gel.

PART NUMBER	DESCRIPTION	CAPACITY IN LITERS
021-600	SA90	1600
021-601	SA100-1	2400
021-602	SA100-2	3800
021-603	SA100-3	5700
021-604	SA100-4	7600
021-605	SA100-5	9600
021-606	SA100-6	11600

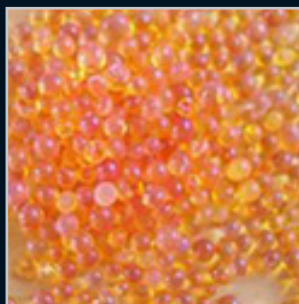

Amber Silica Dehydrating Beads

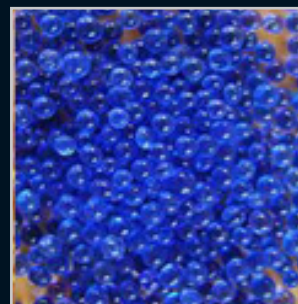

Blue Silica Dehydrating Beads

PART NUMBER	DESCRIPTION
001-056	Blue Silica Dehydrating Beads (per kg)
001-306	Amber Silica Dehydrating Beads (per kg)

Enclosures

Hinges

Locks

Handles

Accessories

Rotary Operating
Handles

Insulators

Transformer
Equipment

Index

Enclosures
Hinges
Locks
Handles
Accessories
Rotary Operating Handles
Insulators
Transformer Equipment
Index

Magnetic Oil Gauge

Buchholz Relay

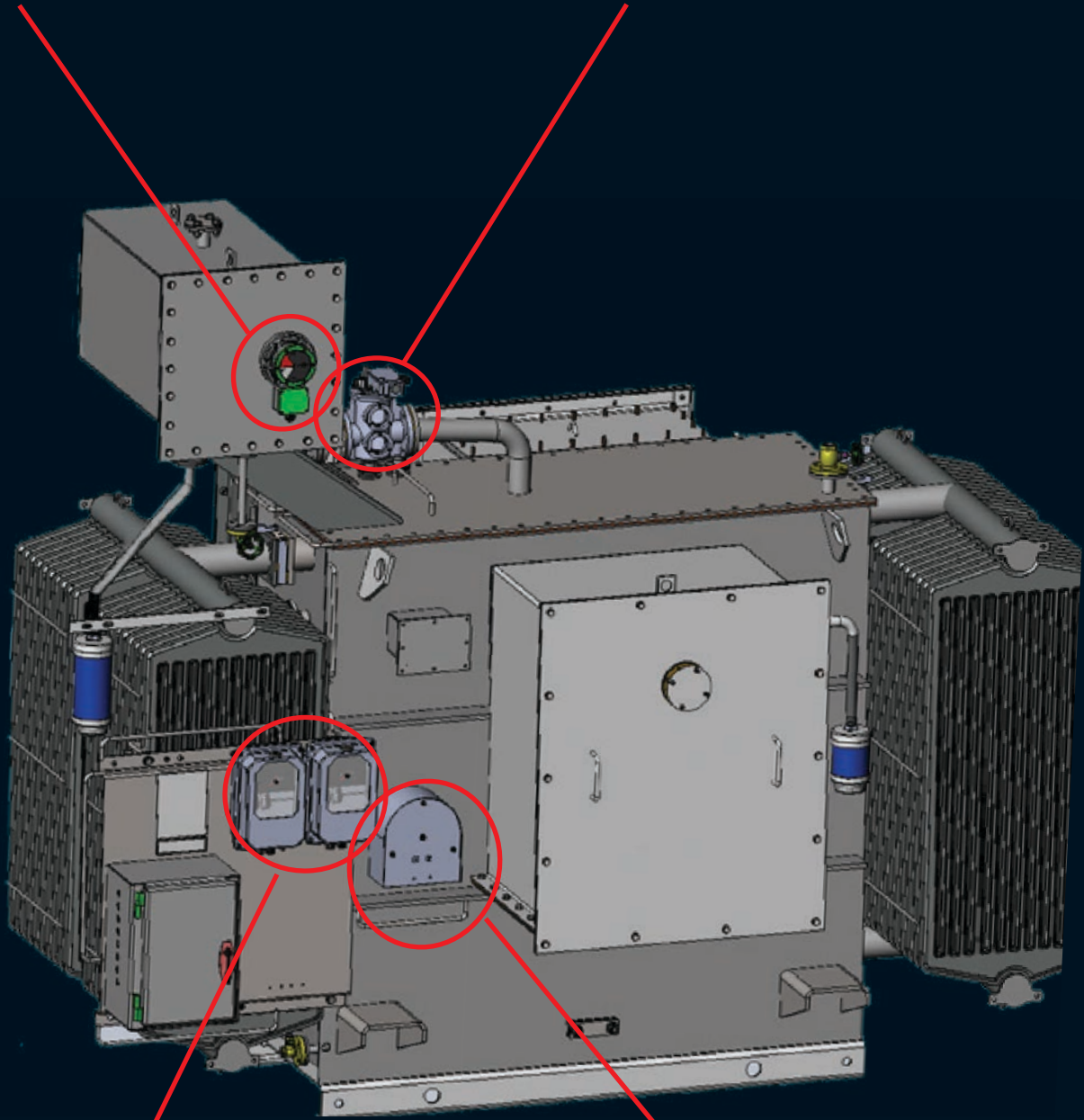

Thermometers

Pressure Relief Valves

Indication Only Thermometers



PART NUMBER	DESCRIPTION	RANGE (Deg Celcius)
021-002	Thermometer BM80	0 to 120
021-003	Thermometer BM100	0 to 120

Thermometers with Contacts (for Telemetry)



PART NUMBER	DESCRIPTION	RANGE (Deg Celcius)	NO. OF CONTACTS	TYPE OF CONTACT	BULB TYPE
021-012	Thermometer F035-AKM Bi Metal 2C	0 to 120	2	Change Over	Direct Mount
021-005	Thermometer 1184	0 to 120	2	Normally Open	Direct Mount
021-008	Thermometer MTVT 84	0 to 120	2	Change Over	Direct Mount
021-006	Thermometer 1187	0 to 120	2	Normally Open	1.5m Capillary
021-004	Thermometer MSRT 100	0 to 120	2	Change Over	1.5m Capillary
021-018	Thermometer 1187-T Spring mounted	0 to 120	2	Normally Open	1.5m Capillary

Enclosures

Hinges

Locks

Handles

Accessories

Rotary Operating Handles

Insulators

Transformer Equipment

Index

Enclosures

Hinges

Locks

Handles

Accessories

Rotary Operating Handles

Insulators

Transformer Equipment

Index



PART NUMBER	DESCRIPTION	RANGE (Deg Celcius)	NO. OF CONTACT	TYPE OF CONTACT	BULB TYPE
021-013	Thermometer F036-AKM Oti 2C 5M	0 to 120	2	Change Over	5m Capillary
021-014	Thermometer F036-AKM Wti 2C 5M	0 to 120	2	Change Over	5m Capillary
021-015	Thermometer F036-AKM Oti 4C 12M	0 to 120	4	Change Over	12m Capillary
021-016	Thermometer F036-AKM Wti 4C 12M	0 to 120	4	Change Over	12m Capillary

Pocket Housing and Boss Assembly



Remarks:
Suggested tank hole size 27mm Diameter.

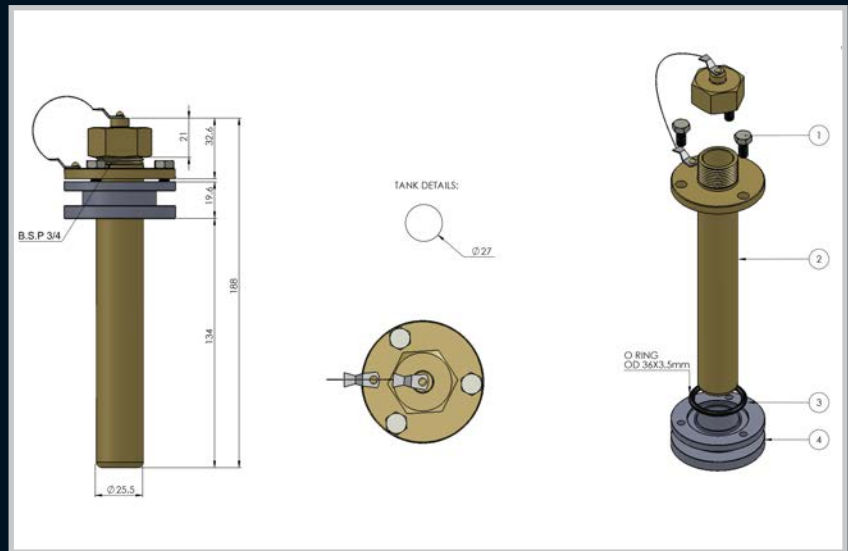

PART NUMBER	DESCRIPTION
021-001	Temperature Pocket Housing and Boss

BS 25

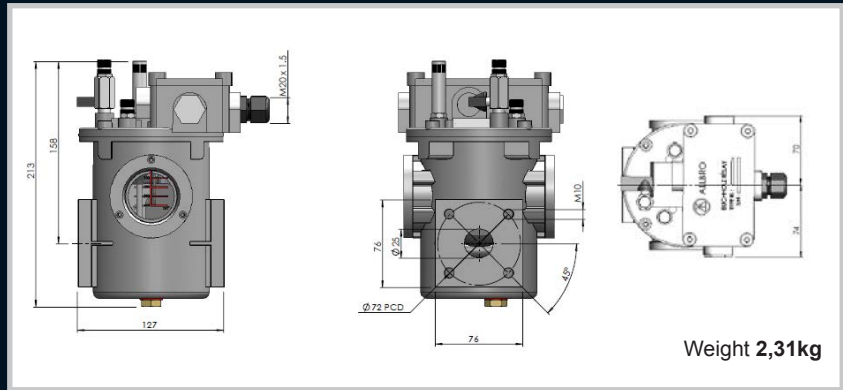

Remarks:

- MA = Magnetic - normally open contacts
- HA = Mercury - normally open contacts

PART NUMBER	DESCRIPTION
021-114	Buchholz Relay Model BS25HA
021-115	Buchholz Relay Model BS25MA
021-115/E	Buchholz Relay BS25MA / E
021-400	Buchholz Valve 25mm
021-426	Buchholz Valve 25mm (60mm FTF)

BS 50

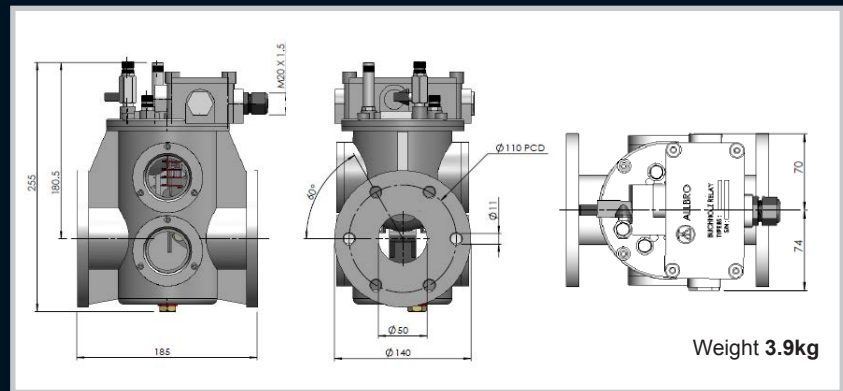

Remarks:

- MA = Magnetic - normally open contacts
- HA = Mercury - normally open contacts

PART NUMBER	DESCRIPTION
021-116	Buchholz Relay Model BS50HA
021-117	Buchholz Relay Model BS50MA
021-117/E	Buchholz Relay BS50MA / E
021-401	Buchholz Valve 50mm
021-427	Buchholz Valve 50mm (60mm FTF)

BS 80

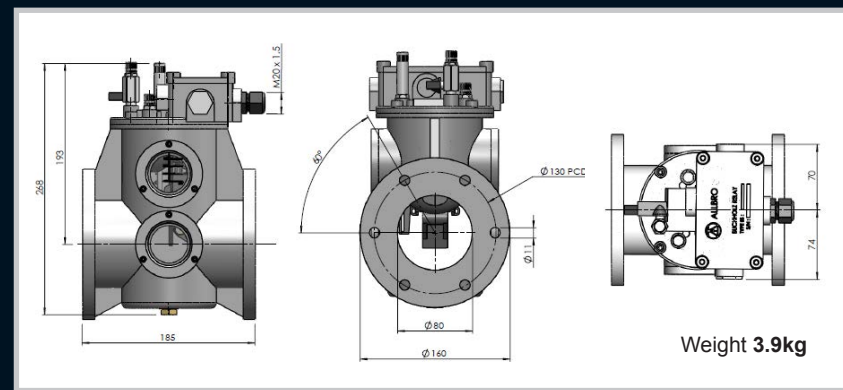

PART NUMBER	DESCRIPTION
021-119/E	Buchholz Relay BS80MA / E
021-428	Buchholz Valve 80mm (60FTF)

Enclosures

Hinges

Locks

Handles

Accessories

Rotary Operating
Handles

Insulators

Transformer
Equipment

Index

Enclosures	<p>The generation of gas in an oil filled transformer is a clear indication of a problem. The gas may be a result of the following:</p> <ul style="list-style-type: none"> • Decomposition / degradation of solid , or liquid insulation inside the transformer due to overheating, or arcing. • From the outside towards the pipeline. • From the oil itself due to unsatisfactory de-gassing prior to filling.
Hinges	<p>Rapid oil movement in the pipeline towards the conservator is caused by an internal arc, short circuit, or hot spot which must be correctly addressed.</p> <p>Oil leaks from the transformer are environmentally unacceptable and a fire hazard will lead to transformer failure.</p>
Locks	<p>To indicate any of the above malfunctions we have developed a Buchholz relay to comply fully with the latest CENELEC EN 50216-1 and EN 50216-2 standards.</p> <p>The relay incorporates the very latest technology in its construction.</p> <p>PRINCIPAL OF OPERATION</p>
Handles	<p>The Buchholz relay is sited in the pipework between the transformer and its conservator and it is filled with oil during normal transformer operation. When gas is generated in the transformer it rises towards the conservator and collects in the upper chamber of the relay. The oil level drops and the top float triggers alarm switch.</p> <p>Gas shall not freely pass from the relay body and escape into the pipework before the alarm contact has operated. The trip contact shall operate at a steady oil flow as indicated in Table 3.</p>
Accessories	<p>This operation shall not be adversely affected when the alarm contact has already closed and gas is escaping freely. In the event of an oil leak the Buchholz relay will only operate after the conservator has exhausted all of its oil. In order to check this eventually it is recommended that an RDR MK II automatic shutter valve is fitted between the Buchholz and the conservator.</p> <p>Specific information on this product are available on request.</p> <p>CONSTRUCTION</p>
Rotary Operating Handles	<p>The Buchholz relay is an assembly of two machined aluminium alloy castings that effect a perfect oil seal.</p> <ol style="list-style-type: none"> 1) The main body of the relay is fitted with tempered glass inspection windows with graduated scale markings in cubic centimeters to indicate the internal volume. The oil drain plug is located at the bottom of the main body. 2) The top cover carries the frame which contains the moving parts of the relay. These comprise the two floats and their associated switches encapsulated in glass bulbs, one calibrated flow valve and two permanent magnets.
Insulators	<p>The cover carries:</p> <ol style="list-style-type: none"> (4) a gas discharge valve with G1/8" in male thread with protective cap. (5) A valve for pneumatically testing the alarm and insulation circuits, with protective cap. (2) A push rod for mechanically tripping the alarm and the insulation circuits, with protective cap. <p>A terminal box which as standard contains 4 numbered M6 terminals and one earth terminal.</p>
Transformer Equipment	
Index	

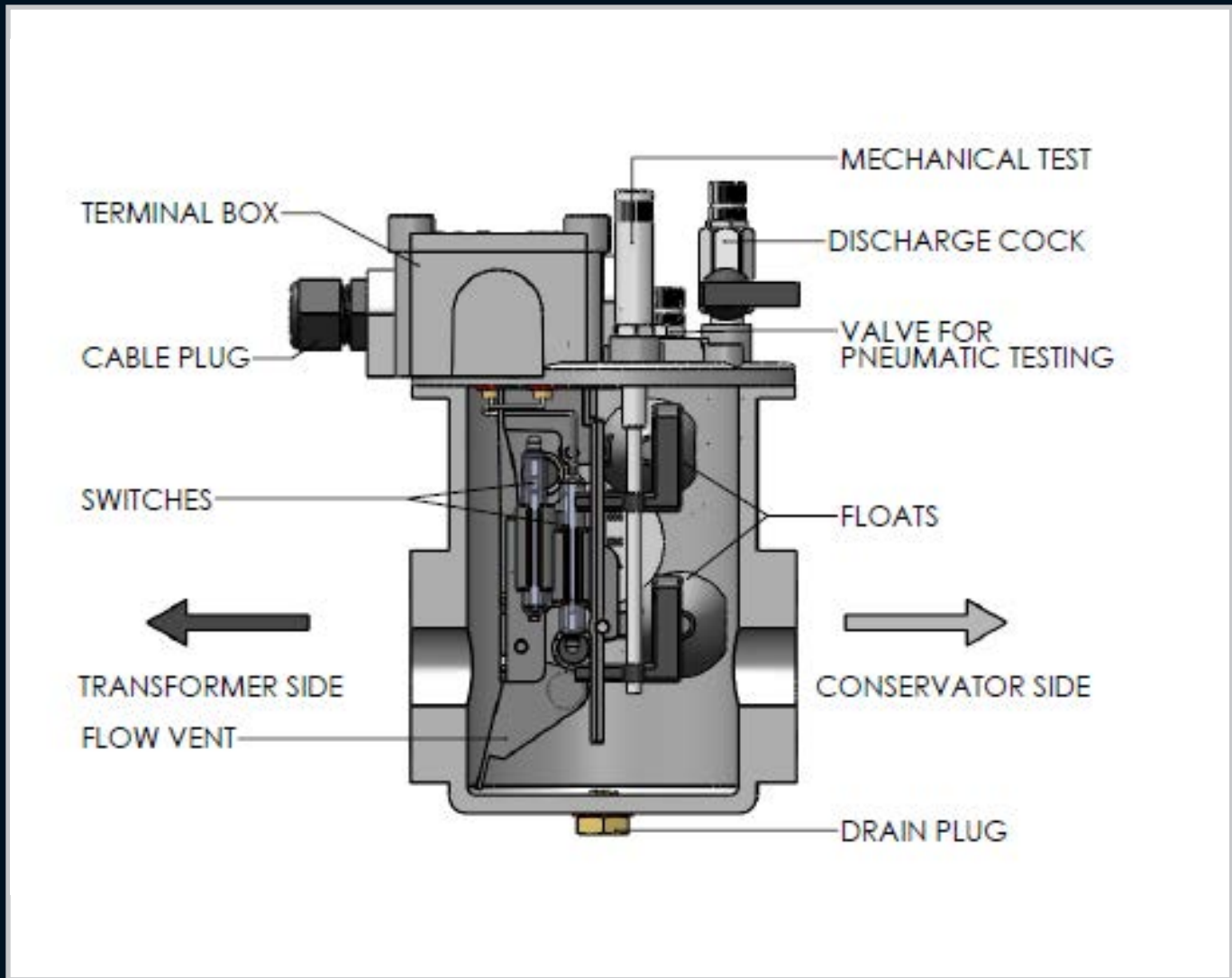

EXTERNAL COATING AND PROTECTION

To the external aluminium alloy parts is given a phosphate treatment prior to applying one coat of vinyl enamel, colour RAL 7001. This treatment has proved more than satisfactory over the years for the majority of applications including desert and tropical situations.

However, in particularly severe applications (>500h salt fog) such as applications in corrosive atmospheres (acids) a suitable epoxy primer is recommended. (This should be discussed at the time of selection).

All external brass fittings are plated and all nuts are made in stainless steel.

Enclosures

Hinges

Locks

Handles

Accessories

Rotary Operating
Handles

Insulators

Transformer
Equipment

Index

Enclosures

RELAY SELECTION

The size and type of relay to be used will depend on the transformer rating and oil volume. Suggestions are given in the following table but the final choice is often as a result of the transformer manufacturers experience.

MVA TRANSFORMER POWER	NOMINAL DIAMETER
Up to 5	25
From 5 up to 20	50
From 20 to 50	80

Hinges

TECHNICAL DATA

Locks

- The relay pipework is typically mounted at 2,5 degrees to the horizontal. A positive inclination of up to 5 degrees to the horizontal axis is admissible.
- Operating pressure - 1 bar, tested to 2,5 bar for 2 minutes at 100 deg C.
- Gas volume to trip alarm:

BUCHHOLTZ RELAY TYPE	GAS VOLUME NECESSARY TO TRIP THE ALARM
BS 25	170+230
BS 50, BS 80	250+300

Handles

- Rate of oil flow in m/s to trip insulation. In the following table standard values are highlighted with an 'O' available, on request with an 'X' and not available with a '/'. +/- 15% tolerance at 20°C with oil viscosity according to IEC296.

INSIDE PIPE DIAMETER	1,0 m/s	1,5 m/s	2,0 m/s
25	o	x	x
50	o	x	x
80	o	x	x

Accessories

Rotary Operating Handles

- The relay operates within 0,5 seconds.
- Oil temperature between -25 and +115 deg C.
- Ambient temperature between -25 and +60 deg C.
- Degree of Protection IP65 to EN 60529.

SWITCH ELECTRICAL DATA

Rated switch current is 2 A r.m.s. with max. 10 A r.m.s. as short term 30 ms current value. Breaking power is specified in the following table:

VOLTAGE	CURRENT	BREAKING POWER
220 Vd.c. (min. 12V)	2 A for 10000 maneuvers	250 W
230 V a.c. (min.12V)	6 A for 1000 maneuvers	400 VA

Insulators

Transformer Equipment

Dielectric contact voltage as specified in the following table:

	SHORT TERM INDUSTRIAL FREQUENCY LEAKAGE TEST Kv / 1min. (r.m.s)	RESISTANCE VOLTAGE PER PULSE Kv (peak)
Between circuits and ground	2.5	5
Across open contacts	1	3

Index

The following Type Tests have been performed on the relay.

- Measurement of the volume of gas necessary to trip the alarm.
- 500 hr salt fog.
- Electromagnetic Field Test. Relay does not trip in field strength up to 25 mT (ref EN 50216-2).
- Stationary sinusoidal mechanical vibrations. Tests according to EN 60721-3-4 standards have been performed.
 - a) class 4M4 (4M6 on request) vibration test applied in sites where vibrations are transmitted from machinery and vehicles. Not suitable for machines exposed to high vibration and shock levels. Three-axis movement was impressed to the relay using special equipment with stationary sinusoidal vibrations from 2 to 200 Hz. Movement had a constant 3 mm (6 mm peak-peak) amplitude in the range from 2 to 9 Hz whereas above this frequency it had constant 10 m/s² acceleration. The alarm and release switches did not trip.
 - b) non-stationary vibration tests with vertical shock with 100 m/s² acceleration with type I spectrum (duration 11 ms) as shown in the graph below. Alarm and release contacts did not trip. On demand we are able to manufacture Buchholz relays with special features and test values higher than the ones stated above.

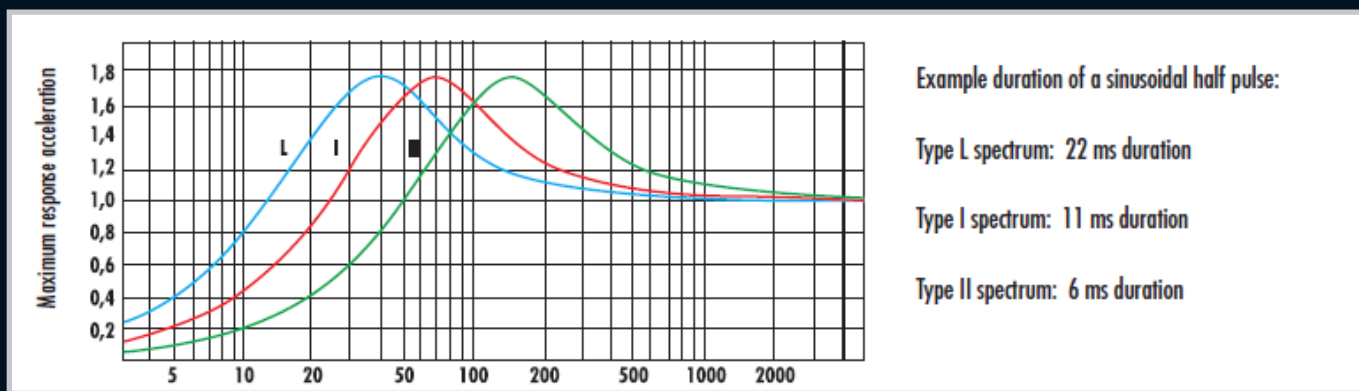

- A seismic test was also performed according to EN 50216-1 standards that refers to EN 60068-3-3 class 0, level 2 standards. The test consists of application of a 9 m/s² horizontal acceleration and a 4.5 m/s² vertical acceleration, increasing frequency one octave per minute. No activation of alarm or release switches was encountered.
- Pressure Withstand Test 2.5 bar for 2 minutes with oil at 100 deg C.
- Vacuum Withstand Test of 2500 Pa for 24 hrs.
- Rate of oil flow test to operate trip contacts, (as shown in table 3).
- Test to show the relay is insensitive to oil flow from conservator to transformer.
- Electrical tests per table 5.

ROUTINE TESTS

The following Routine Tests are applied to all relays.

- Hydraulic seal test in mineral oil at 90 deg C and 100 kpa pressure for 30 minutes.
- Contact operation via mechanical push rod.
- Contact operation by lowering the oil.
- Rate of oil flow to trip contacts.
- Electrical withstand test between contacts (as table 5).
- Electrical withstand test between contacts and earth (as table 5).

An individual routine Test Report is shipped with each relay

RELAY OPERATING TEST

The following site Tests can be performed when the relay is installed on the transformer:

The Alarm and Trip contacts can be tested manually by the push rod (2) - mechanical test, or (only for alarm contact) by the introduction of air into the relay through valve (5) - pneumatic test.

A bicycle pump can be utilised for this test.

To effectively test the rate of flow of oil is a complex test requiring specialised equipment. Should this test be required other than as a type test then we can perform this on request at the time of the order.

INSTALLATION INSTRUCTIONS

The following installation procedures must be observed for proper relay operation:

- The red arrow on the relay must point towards the conservator.
- The relay must always be full of oil, which means that the minimum oil level in the conservator must be higher than the relays breather valve.
- The recommended inclination of the relay pipework is 2.5 degrees from the horizontal.
- The pipe from the transformer to the relay must exit the transformer at the highest point.
- The pipeline upstream from the relay has to be straight and with a length equal to 5-10 times the pipeline diameter, at least.

Down stream from the relay, pipeline length has to be 3 times the pipeline diameter, only. It must rise up towards the conservator.

Enclosures
Hinges
Locks
Handles
Accessories
Rotary Operating Handles
Insulators
Transformer Equipment
Index

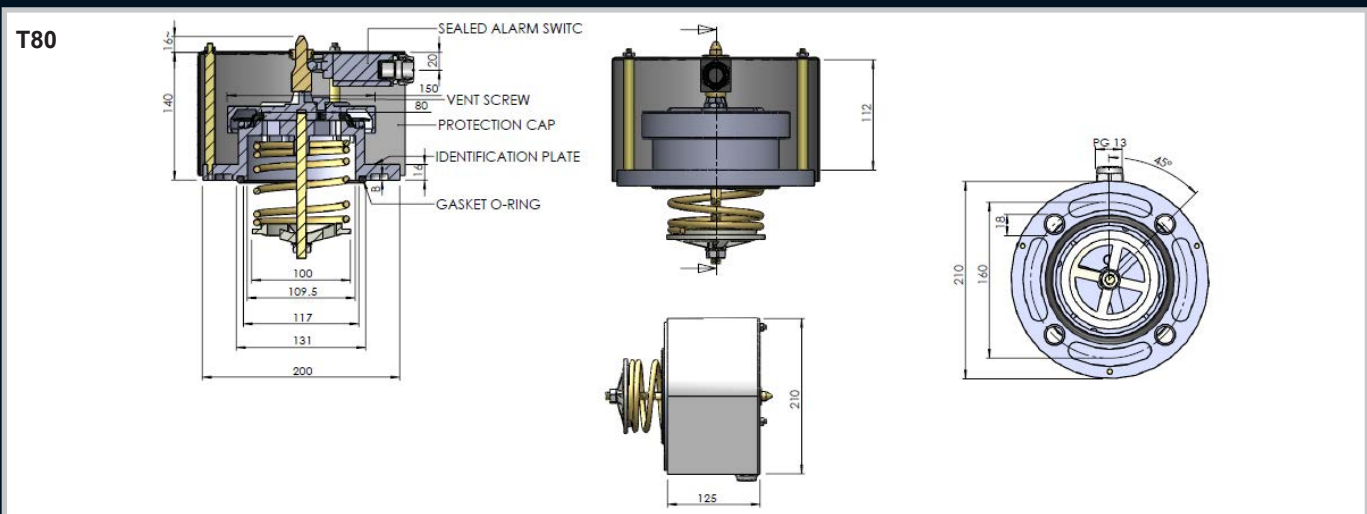
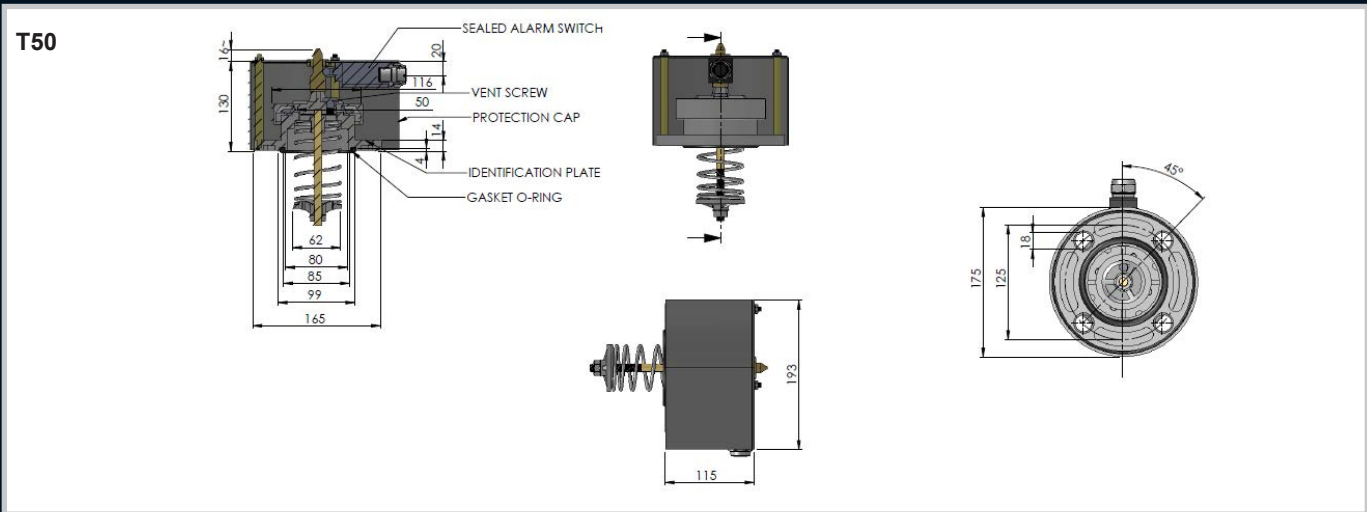
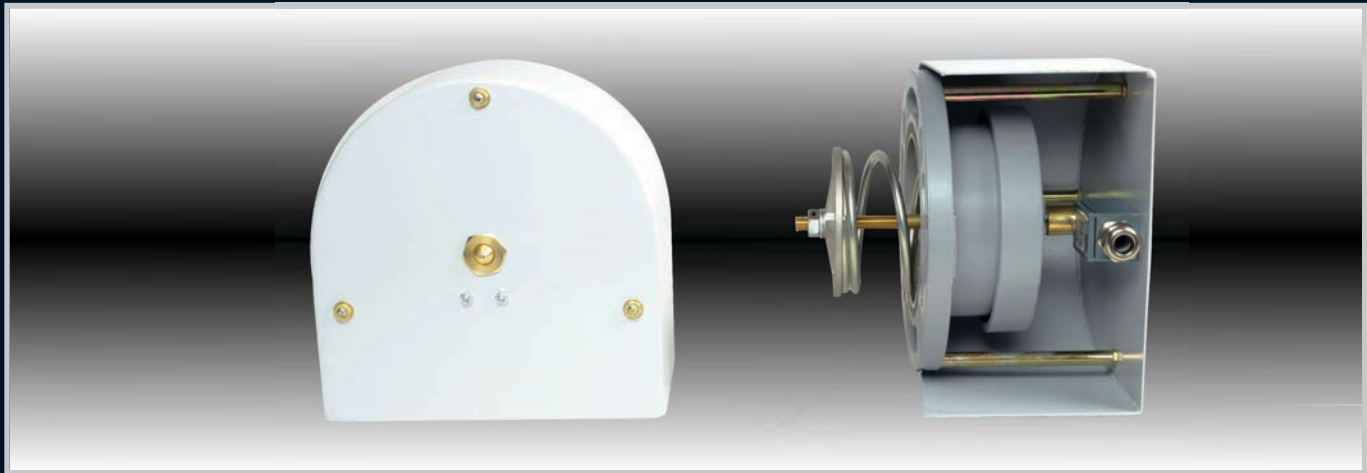

PART NUMBER	DESCRIPTION	Operating Pressure	Maximum Capacity	Switch I max	Switch V max	Switch Config
021-200	T50 Pressure Relief Valve	70Kpa	3000 L	5A	500VAC	1 C / Over
021-201	T80 Pressure Relief Valve	70Kpa	9000 L	5A	500VAC	1 C / Over

Remarks:

We can set T50 and T80 devices to the following pressures on request: 55Kpa, 90Kpa, 125Kpa

Enclosures

Hinges

Locks

Handles

Accessories

Rotary Operating Handles

Insulators

Transformer Equipment

Index

Enclosures	<p>ALLBRO “T” valves are used to control pressures inside tanks. They are used where accidental, instantaneous and uncontrolled increases in pressure may create the danger of explosion. They are designed to discharge the pressure increases that have taken place to the exterior in a very short time period (a few thousandths of a second). They are widely used in the metal tanks of oil-cooled electric transformers. Sudden and violent short circuits inside these tanks, in fact, instantly generate an enormous amount of gas with a great increase in interior pressures. If the pressure cannot discharge to the exterior there is danger that the transformer may explode, with all the possible harm and damages this may cause. This danger can be prevented by installing one or more valves with discharge sizes proportional to the volume of oil contained in the transformer. It is always good practice to install these valves in all situations where internal pressure values must not exceed specific safety limits.</p>
Hinges	<p>CONSTRUCTION</p> <p>Our valves are totally protected against external corrosion and against penetration of foreign bodies between cover and protective cap. This ensures perfect operating efficiency even for extended periods of time.</p>
Locks	<p>TYPE “T” VALVES</p> <p>These consist of a flanged body and a corrosion-proof aluminium alloy disk. A brass rod that holds the spring is applied to the central part of the disk. There are two gaskets in the valve: a special shaped upper gasket and a lip seal.</p>
Handles	<p>When the valve is closed the upper gasket is pressed against the disk. The shape of the gasket permits a perfect seal even if the disk lifts 1-2 mm. The disk also makes a seal against the lip seal gasket as it moves upwards. If, due to interior pressure, the disk rises beyond this amount then the upper seal is no longer maintained while the lip seal remains. At this instant the surface of the washer invested by internal pressure is multiplied in area as is the total force applied on the spring. This causes total and instantaneous opening of the valve which consequently discharges excess pressures to the exterior. When pressure has been discharged the disk, pushed back by the spring, lowers down and closes the valve. As the disk moves downwards it first closes against the side gasket and then against the upper gasket. This latter gasket, because of its special shape, is pressed down 1-2 mm. and the disk moves further down, breaking the seal on the lip seal gasket. This releases any pressure that may have been trapped between the two gaskets. Now the valve is ready to intervene again.</p>
Accessories	<p>Total valve opening</p> <p>Valve opening is total each time the valve operates for pressure settings between 20 and 90kPa. The discharge opening area, for each valve operation, is equal to that for higher pressure settings even when pressure settings are lower than 20 kPa. If, however, pressures are generated inside the tank that are much higher than the setting then the spring, further compressed, allows the closing disk to create even larger discharge areas when it operates.</p>
Rotary Operating Handles	<p>Operating performance</p> <p>Nominal operating pressure: the pre-fixed overpressure value shall be agreed between supplier and purchaser within the standard range from 20 up to 90 kPa, with 10 kPa steps, with a tolerance of - 5 kPa to + 7 kPa.</p>
Insulators	<p>Routine tests</p> <p>It is necessary to carry on operational tests, with compressed air:</p> <ul style="list-style-type: none"> · to check the correct functioning of the device at the operating pressure value · to check the functioning of the optic signal and of the electric contacts.
Transformer Equipment	<p>INSTALLATION GUIDELINES</p> <p>Our valves come in 2 sizes and have different discharge areas. This allows users to select the type that is best suited for the volume of oil contained in the tank. The following gives guideline values:</p> <p>Volume of oil tank: Type of valve up to 3000 dm³ 50 T* up to 9000 dm³ 80 T*</p> <p>* These guideline sizes are based on experience.</p>
Index	<p>We recommend using multiple valves when oil volumes exceed these levels. It is always good practice to use multiple valves with smaller discharge areas rather than a single valve with a large area. The reason for this, in the case of transformers, is that it is better to install one valve above each winding column since these are the points where maximum interior pressures are generated in case of a short circuit. Instantaneous valve opening implies direct contact between the closing disk and oil. For this reason the valves are equipped with a screw to bleed out air that may accumulate during oil tank filling procedures.</p>

PRESSURE SETTINGS

Standard pressure settings, for each type of valve, may vary from 20 to 90 kPa (approximately 0.2-0.9 Atm.). Valves with non-standard pressure settings are manufactured on request.

GUARD AGAINST JETS OF HOT OIL

It is good practice, to prevent harm to persons or property from violent jets of hot oil evacuating from the valve, for valve discharges to be directed towards points properly designed to receive the discharge. Our valves are furnished with a steel powder coated protective cap for this purpose. This cap, which does not offer any impediment to the discharge, permits you to direct the discharge flow towards the point you desire.

Detailed assembling instructions are supplied with the equipment.

Please feel free to contact our Sales Dept and ask for a copy of the working test film.

ELECTRIC SIGNAL SWITCH

A "valve open signal" contact may be mounted on request. This is a fast tripping limit switch with switching contact contained inside a watertight casing. This contact is installed so that it acts simultaneous with the visual signal. This switch has the following characteristics:

Voltage	Uninterrupted current (making capacity)	Interrupted current (breaking capacity)
24 VDC to 220 VDC	2 A	100 Ma L/R<40 ms
230 VAC	2 A	2 A cosφ > 0.5

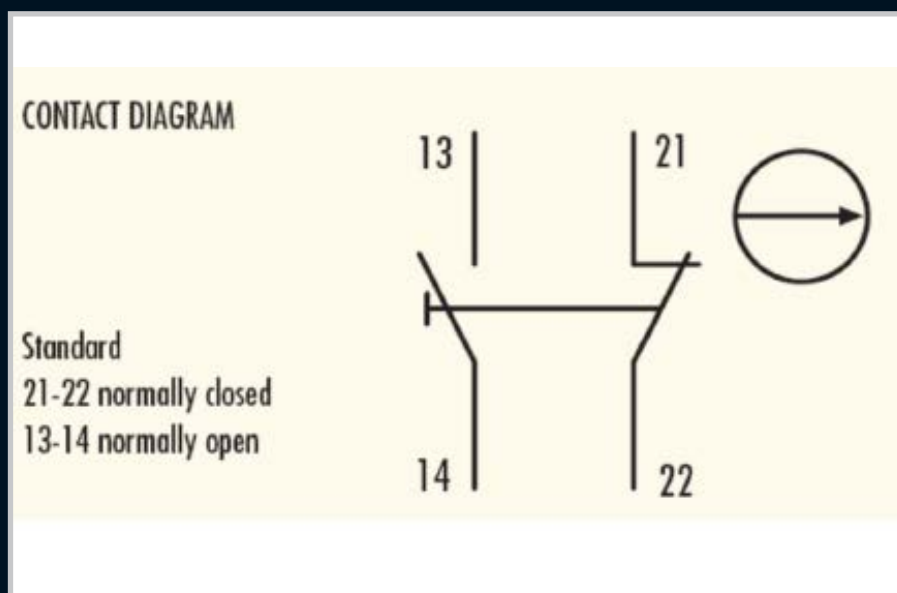

EXTERNAL SURFACE PROTECTION

External surfaces are protected against weather corrosion. Aluminum alloy components are non-corroding and their surfaces are protected with a double layer of paint offering highlevel protection against all atmospheric agents and resisting temperature variations between -40 °C and +100 °C. The plastic protection cap and stainless steel screws offer further assurance of proper valve operation.

Enclosures

Hinges

Locks

Handles

Accessories

Rotary Operating Handles

Insulators

Transformer Equipment

Index

Enclosures



Hinges

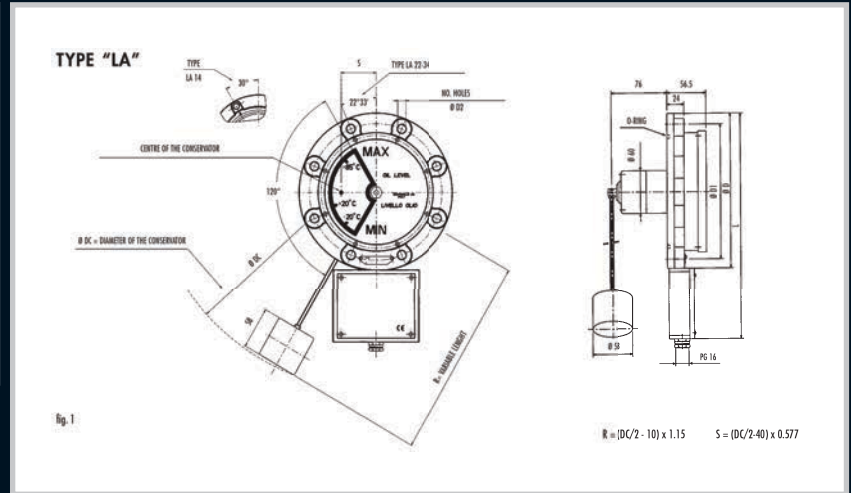

Locks

PART NUMBER	DESCRIPTION	ø D	ø D1	ø D2	NO. OF HOLES	L	O.RING TYPE	WEIGHT (kg)	R STANDARD
021-300	LA140	140	125	7	6	245	O.R. 186 (6362)	1.4	max. 370
021-301	LA220	220	190	11.5	8	325	O.R. 221	2.3	max. 550

Handles

LEVEL GAUGES WITH MAGNETIC JOINT

The level with a magnetic joint are composed of a sturdy watertight body of aluminium alloy painted against corrosion.

The movement of the float rod and the gauge disk takes place by means of magnetic coupling through an angle of 120°. In this way, for every variation in the level of the liquid there is a corresponding rotation of the magnet with consequent variation of the indication on the dial of the gauge. The gauge disk is coloured white and red.

The system is closed with a screen-printed polycarbonate disk with reference marks corresponding to the levels that the oil should reach at the following temperatures in degrees Centigrade: -20° C, + 20° C, +85° C.

Note: Special dials may be on request.

Accessories

Rotary Operating Handles

READING THE INDICATIONS OF THE VARIOUS LIQUID LEVELS

- Minimum level: when the dial shows all red.
 - Maximum level: when the dial shows all white.
 - Intermediate indications between MAX and MIN: the dial shows part white and part red.
- Remember that the amount of red shown indicates, in portion, the part of the conservator left without liquid.

Insulators

FLOAT MOVEMENT

This may be in the radial direction of the conservator (type "LA").

FLOAT ROD

This is completely threaded. If the length is not specified (distance R in drawing), the standard size indicated on the table is supplied. The rolling float arm is an aluminium tube.

Transformer Equipment

ELECTRIC INDICATION

These level gauges are fitted with microswitches for indicating the minimum and maximum oil level.

ELECTRIC CHARACTERISTICS

- Power supply: 24 to 220 V a.c. or d.c.
- Interruption power: 3 A 125/250 V a.c (resistive)
0,5 A V d.c for inductive load L/R = 40 ms
0,25 A 250 V d.c for inductive load L/R = 40 ms

Index

INDICATING INTERVENTION

The electric microswitches intervene with an advance angle $\leq 5^\circ$ with respect to the indications of the minimum or maximum oil level in the conservator. When there is a double contact on MIN and/or MAX, the second contact intervenes about 5° after the first contact. After installation of the gauges it is possible to check the correct operation of the microswitches and, in general, good operation of all the internal parts of the gauge by proceeding as follows:

- Remove the cap situated in the center of the dial on the front of the level gauge, unscrewing it in an anticlockwise direction.
- Insert a screwdriver in the slot provided and turn the gauge disk until the electric circuit connected to it switches on or off.
- Close the cap again, being particularly careful to position the O-ring (O.R.) correctly under the cap and to screw the cap on quite firmly.

REMARKS

External nuts and bolts made of stainless steel.
 External painting in grey RAL 7001
 Degree of protection: IP 55
 Working temperature.
 All the level gauges are suitable for working with:
 - Oil temperatures between: -25°C and $+120^\circ\text{C}$
 - Environment temperature between: -25°C and $+60^\circ\text{C}$

INDICATIONS FOR ASSEMBLY

The level gauges which have float movement in the radial direction of the container (type "LA") must be fitted offset with respect to the horizontal axis of the conservator (distance "S" in fig. 1) so as to have an exact indication of the minimum and maximum oil level. It is good practice to check operation of the gauge after having fitted it on the conservator.

For further and more detailed information, see the technical information card supplied.

TESTS AND INSPECTIONS

The level gauges are subjected to insulation test towards earth as follows: 2.5 kV AC 50 Hz for 72 seconds. The bodies of the level gauges, after having passed the dimensional inspection and without their internal parts, are tested for watertightness so as to eliminate those that have leaks. Final testing is carried out when the level gauge is completely assembled. The sensitivity of all the signaling movements and the accuracy of their assembly are scrupulously checked.

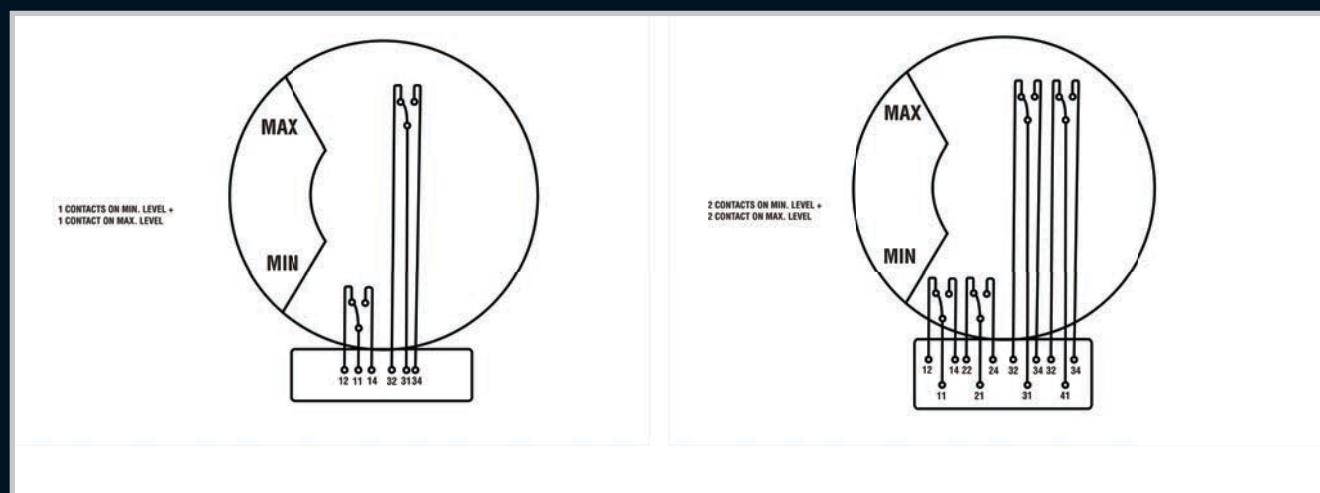

Enclosures

Hinges

Locks

Handles

Accessories

Rotary Operating Handles

Insulators

Transformer Equipment

Index

AKM 44612/44622/44617/44618
Direct mount thermometers
 Control and alarm with switches and optional SCADA output

092 Flow Indicators
 Control alarms and other auxiliary equipment

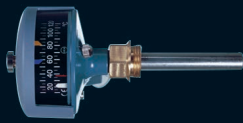

Oil Flow Indicators

XPRD Extra Protection Relief Device LPRD/208/213/216 Large Pressure Relief Devices
 50% more tank protection during overpressure events
 Confidence with the global standard in pressure relief devices



Pressure Relief Valves

900/910 Rapid Pressure Rise Relays
 Protection and detection of dangerous sudden pressure changes



OTIWTI™ Remote mount thermometer (AKIM)
 The next generation thermometer from the global leader



Thermometers

T/Guard Link Optical Hot Spot Module



CAB-699 Fiber Optic Temperature Probe



509 DW Intelligent Transformer Monitor with Direct Winding



CON-159 Optical Feedthrough



T/Guard 408 and 408XT Fiber Optic Temperature Monitoring System **COV-121/PLT-201/PLT-202 Junction Box For Tank Wall Plate**



KIT-057 Portable Fiber Optic Thermometer
 Compact fiber optic temperature measurement



Rapid Pressure Rise Relays

Serveron Dissolved Gas Analysers



Neoptix Fibre Monitoring