

Busplug and Busbar Support Range

Low Voltage Switchboard Equipment



Allbro is a manufacturer with more than 40 years experience and 20 000 sqm of production facility. We manufacture key components for the electrical industry and we are a leading supplier of non-metallic enclosures to the industrial, commercial and residential contracting trades.

Allbro is committed to prioritizing clients needs. Our continuous product development, quality control measures, stock holding and speed of delivery, place Allbro in a leading market position in most of the product lines we sell.

Allbro has developed competencies in a variety of complex disciplines. Through vertical integration Allbro has pioneered its own Glass Reinforced Polyester formulations which offer superior strength and durability. A balance between form and function, means that Allbro products are able to go the distance in some of the toughest environments on earth.

Allbro has become a leading innovator in the markets we serve. Several “world first” concepts have been created in the past few years. In house design & tool making capabilities allow the company to rapidly take an idea and turn it into a final product.

In house design and Tooling:

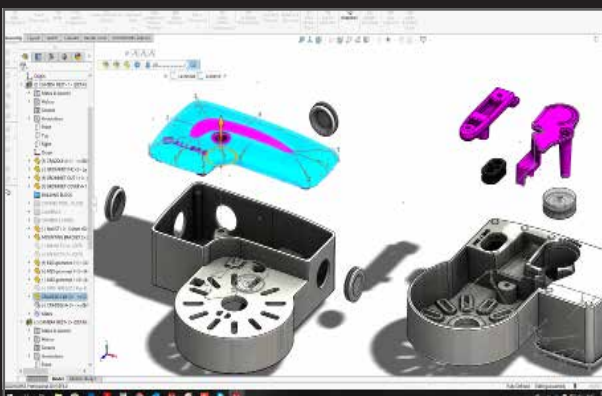
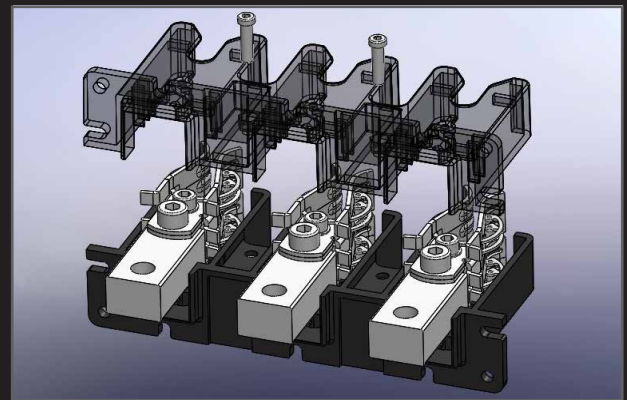
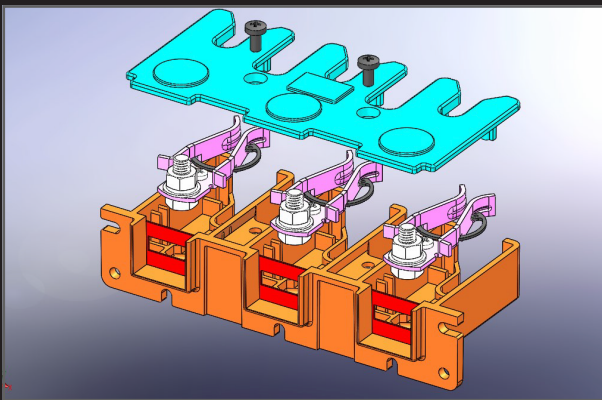

** Examples of various Allbro products in design/tooling phase.*

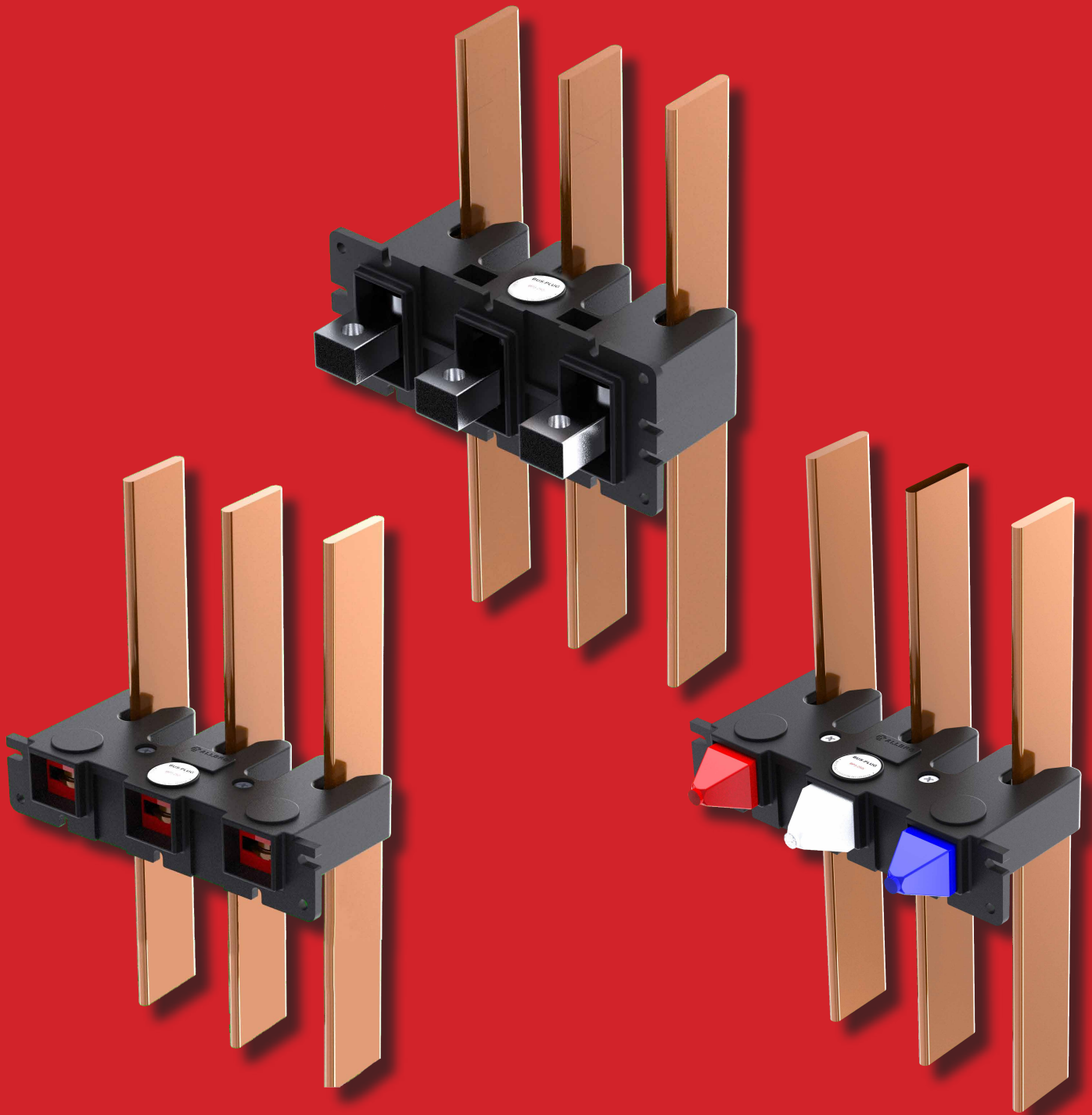

Busplugs

Introduction:

Busplugs provide an Off-Load link that is disconnectable between the Busbar System and the short circuit protection device.

Advantages of Busplugs:

- Busplugs provide a positive means of isolating, allowing for maintenance and repairs to be safely carried out on a withdrawn unit, even with the power still on.
- Completely withdrawable units provide for visible confirmation that the circuit has been isolated.
- Streamlines the changes made to drives and feeders while the switchboard is being constructed.
- Less labour intensive compared to making solid bolt on connections.
- Withdrawable units can be assembled and tested separately from the switchboard and then fitted at a later stage.
- Less labour intensive when changes are required on site, ensuring quick removal and replacement.

Material Construction:

Contacts are made from high conductivity copper, that is press formed into an integral one piece design which allows for a consistent point of contact onto the Busbars.

Copper contacts are silver plated.

Housings are made from 25% glass filled flame retardant Nylon. Glow wire test reports are available.

Each phase is fully segregated due to the innovative design.

Standards and Type Tests

AS/NZ61439.1:2016 (IEC 61439-1) Low Voltage Switchgear and Control gear Assemblies.

The standards require various type tests which include:

- Glow wire test to 960°C
- Short circuit (ICC)
- Mechanical endurance
- Temperature rise
- Dielectric tests
- Clearance and creepage distances
- * Tests Reports are available on request.

Quality ISO 9001:2015

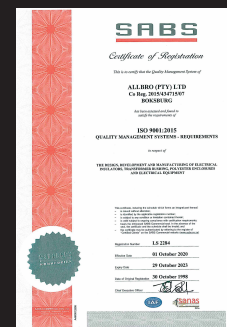

Material Properties:

The Busplug housings are injection moulded from Glass Filled Nylon.

Properties	Units	Method	Results
Density	g./cm ³	ISO 1183	1,36
Water Absorption (23°C-50% RH 24 hrs saturation)	%	ISO 62	1,00
Mold Shrinkage	%	ISO 2577	0,3-0,5
Tensile Strength	MPa	ISO 527	160
Elongation at Break	%	ISO 527	3
Flexural Strength	MPa	ISO 178	230
Flexural Modulus	MPa	ISO 178	8800
IZOD (Notched 23°C)	J/m	ISO 180/1A	140
HDT A (1.82 MPa)	°C	ISO 75	210
VICAT B50 (49 N)	°C	ISO 306	220
UL94 Flammability (1.5mm)	Rating	UL94	V0
Limit Temperature (20.000H)	°C	IEC216	105
Glow Wire Test (2mm)	°C	IEC 695-2-1	960
CTI	V	IEC 112	500
Dielectric Strength	KV/mm	IEC 243-1	20

Busplugs for 6.35mm Busbars

Part Number	Description	Rating	Poles	Connection Type
BP3-63i	BusPlug Connector 3PH 63A Internal	63A	3P	Internal
BP3-63e	BusPlug Connector 3PH 63A External			External
BP4-63i	BusPlug Connector 4PH 63A Internal		4P	Internal
BP4-63e	BusPlug Connector 4PH 63A External			External
BP1-250e	BusPlug Connector 1PH 250A External	250A	1P	External
BP3-250i	BusPlug Connector 3PH 250A Internal		3P	Internal
BP3-250e	BusPlug Connector 3PH 250A External			External
BP4-250i	BusPlug Connector 4PH 250A Internal		4P	Internal
BP4-250e	BusPlug Connector 4PH 250A External	External		
BP1-400e	BusPlug Connector 1PH 400A External	400A	1P	External
BP3-400i	BusPlug Connector 3PH 400A Internal		3P	Internal
BP3-400e	BusPlug Connector 3PH 400A External			External
BP4-400i	BusPlug Connector 4PH 400A Internal		4P	Internal
BP4-400e	BusPlug Connector 4PH 400A External	External		
BP1-800e	BusPlug Connector 1PH 800A External	800A	1P	External
BP3-800e	BusPlug Connector 3PH 800A External		3P	
BP4-800e	BusPlug Connector 4PH 800A External		4P	
BP3-800et	BusPlug Connector 3PH 800A External Threaded		3P	External Threaded
BP4-800et	BusPlug Connector 4PH 800A External Threaded	4P		
BP3-1000et	BusPlug Connector 3PH 1000A External Threaded	1000A	3P	External Threaded
BP4-1000et	BusPlug Connector 4PH 1000A External Threaded		4P	
BP3-1200et	BusPlug Connector 3PH 1200A External Threaded	1200A	3P	
BP4-1200et	BusPlug Connector 4PH 1200A External Threaded		4P	

Busplugs for 10mm Busbars

Part Number	Description	Rating	Poles	Connection Type
BP3-63i-10	BusPlug Connector 3PH 63A -10 Internal	63A	3P	Internal
BP3-63e-10	BusPlug Connector 3PH 63A - 10 External			External
BP4-63i-10	BusPlug Connector 4PH 63A - 10 Internal		4P	Internal
BP4-63e-10	BusPlug Connector 4PH 63A - 10 External			External
BP1-250e-10	BusPlug Connector 1PH 250A - 10 External	250A	1P	External
BP3-250i-10	BusPlug Connector 3PH 250A - 10 Internal		3P	Internal
BP3-250e-10	BusPlug Connector 3PH 250A - 10 External			External
BP4-250i-10	BusPlug Connector 4PH 250A - 10 Internal		4P	Internal
BP4-250e-10	BusPlug Connector 4PH 250A - 10 External	External		
BP1-400e10	BusPlug Connector 1PH 400A -10 External	400A	1P	External
BP3-400i-10	BusPlug Connector 3PH 400A - 10 Internal		3P	Internal
BP3-400e-10	BusPlug Connector 3PH 400A - 10 External			External
BP4-400i-10	BusPlug Connector 4PH 400A - 10 Internal		4P	Internal
BP4-400e-10	BusPlug Connector 4PH 400A - 10 External	External		
BP1-800e-10	BusPlug Connector 1PH 800A - 10 External	800A	1P	External
BP3-800e-10	BusPlug Connector 3PH 800A - 10 External		3P	
BP4-800e-10	BusPlug Connector 4PH 800A - 10 External		4P	
BP3-800et-10	BusPlug Connector 3PH 800A - 10 External Threaded		3P	External Threaded
BP4-800et-10	BusPlug Connector 4PH 800A - 10 External Threaded	4P		
BP3-1000et-10	BusPlug Connector 3PH 1000A - 10 External Threaded	1000A	3P	External Threaded
BP4-1000et-10	BusPlug Connector 4PH 1000A - 10 External Threaded		4P	
BP3-1200et-10	BusPlug Connector 3PH 1200A - 10 External Threaded	1200A	3P	
BP4-1200et-10	BusPlug Connector 4PH 1200A - 10 External Threaded		4P	

Busplug Cones

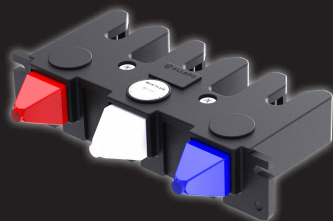

Part Number	Description	Material	Max Cable Size	Max BB Size
BP-CONE/Red	Busplug Cone Red	PVC Flame Retardant (V0)	50mm ²	20 x 6
BP-CONE/White	Busplug Cone White			
BP-CONE/Blue	Busplug Cone Blue			
BP-CONE/Black	Busplug Cone Black			

3/4 Pole - 63A - 400A

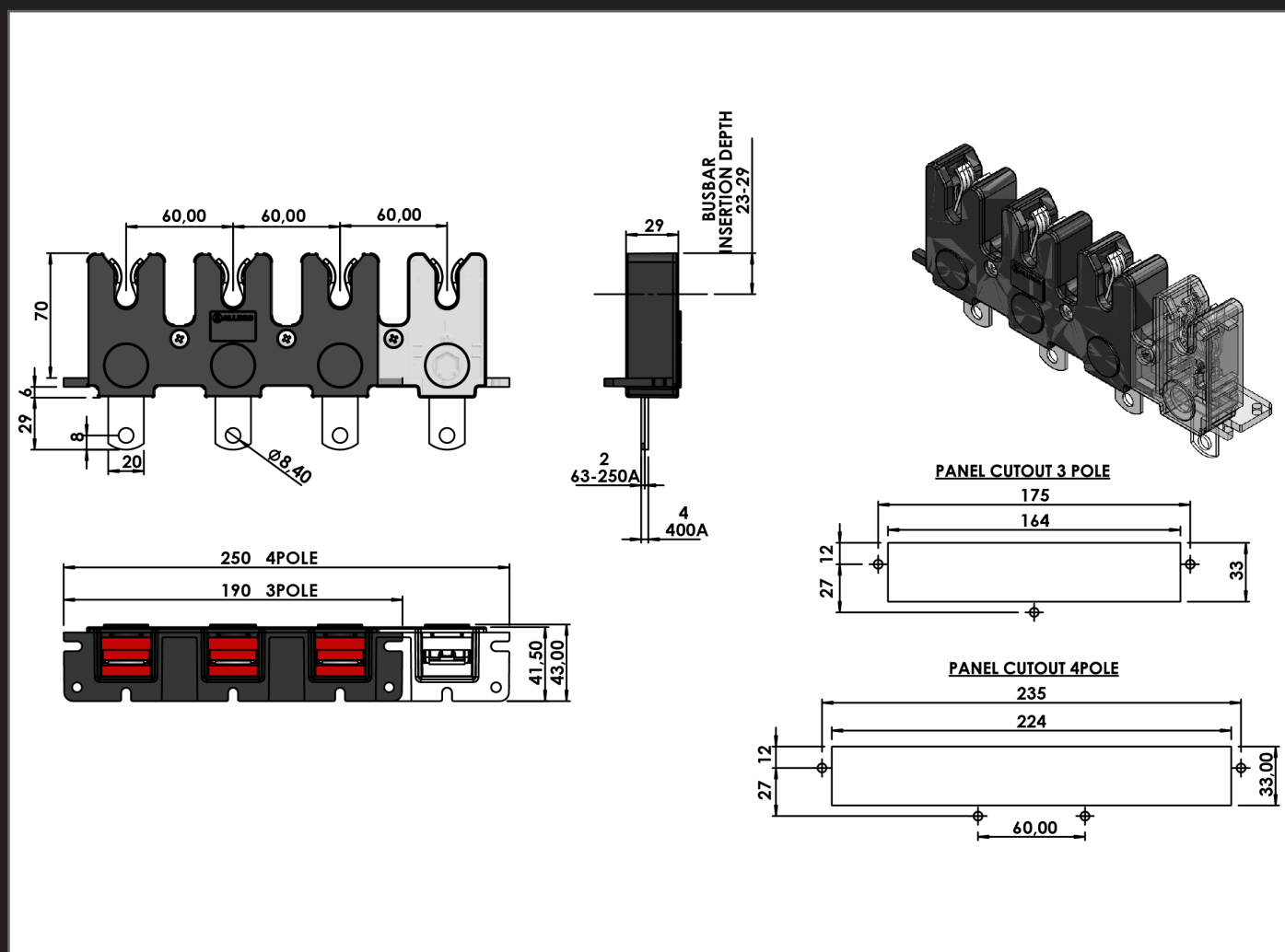

* PDF & 3D drawings are available on request.

3/4 Pole - 800A

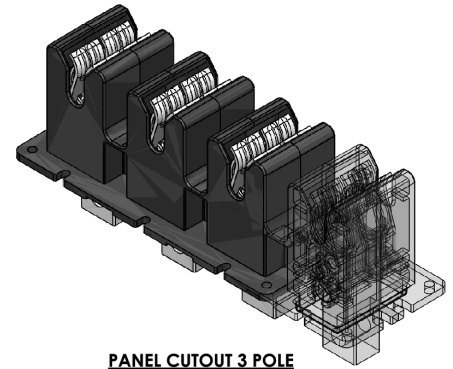
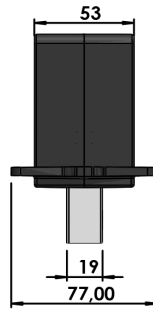
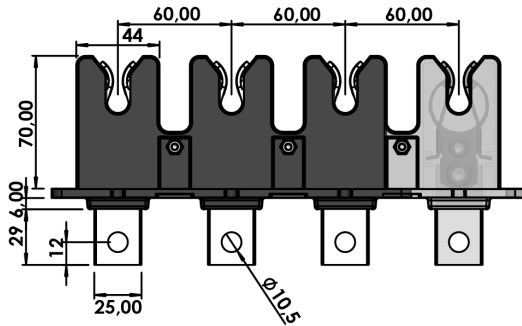

PANEL CUTOUT 3 POLE

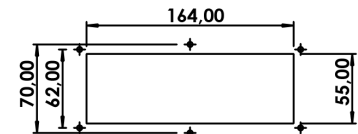
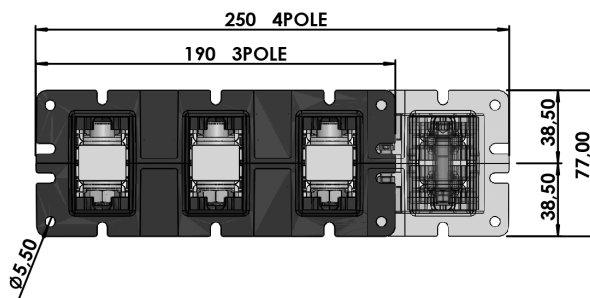

PANEL CUTOUT 4POLE

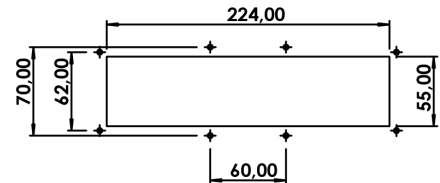

* PDF & 3D drawings are available on request.

3/4 Pole - 1000A

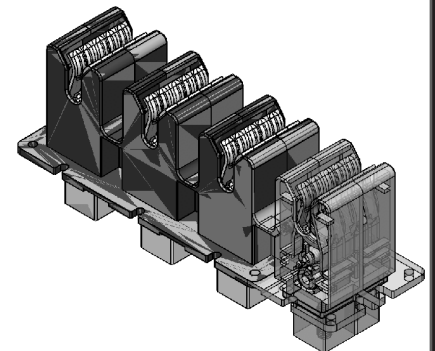
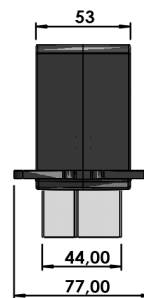
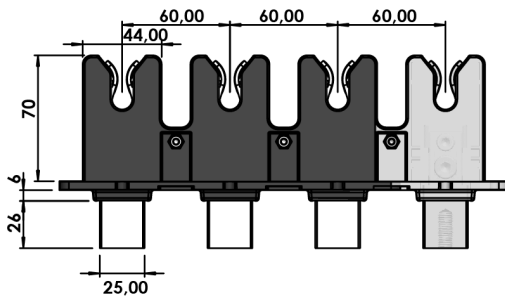

PANEL CUTOUT 3 POLE

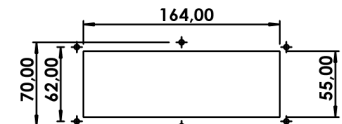

PANEL CUTOUT 4POLE

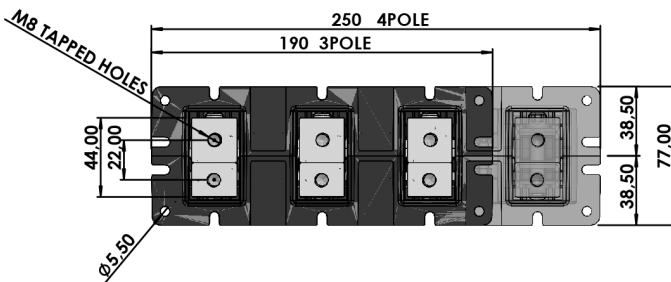
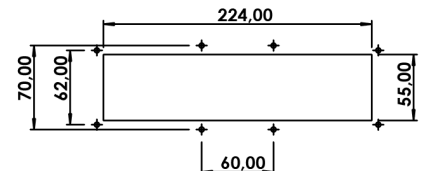

* PDF & 3D drawings are available on request.

3/4 Pole - 1200A

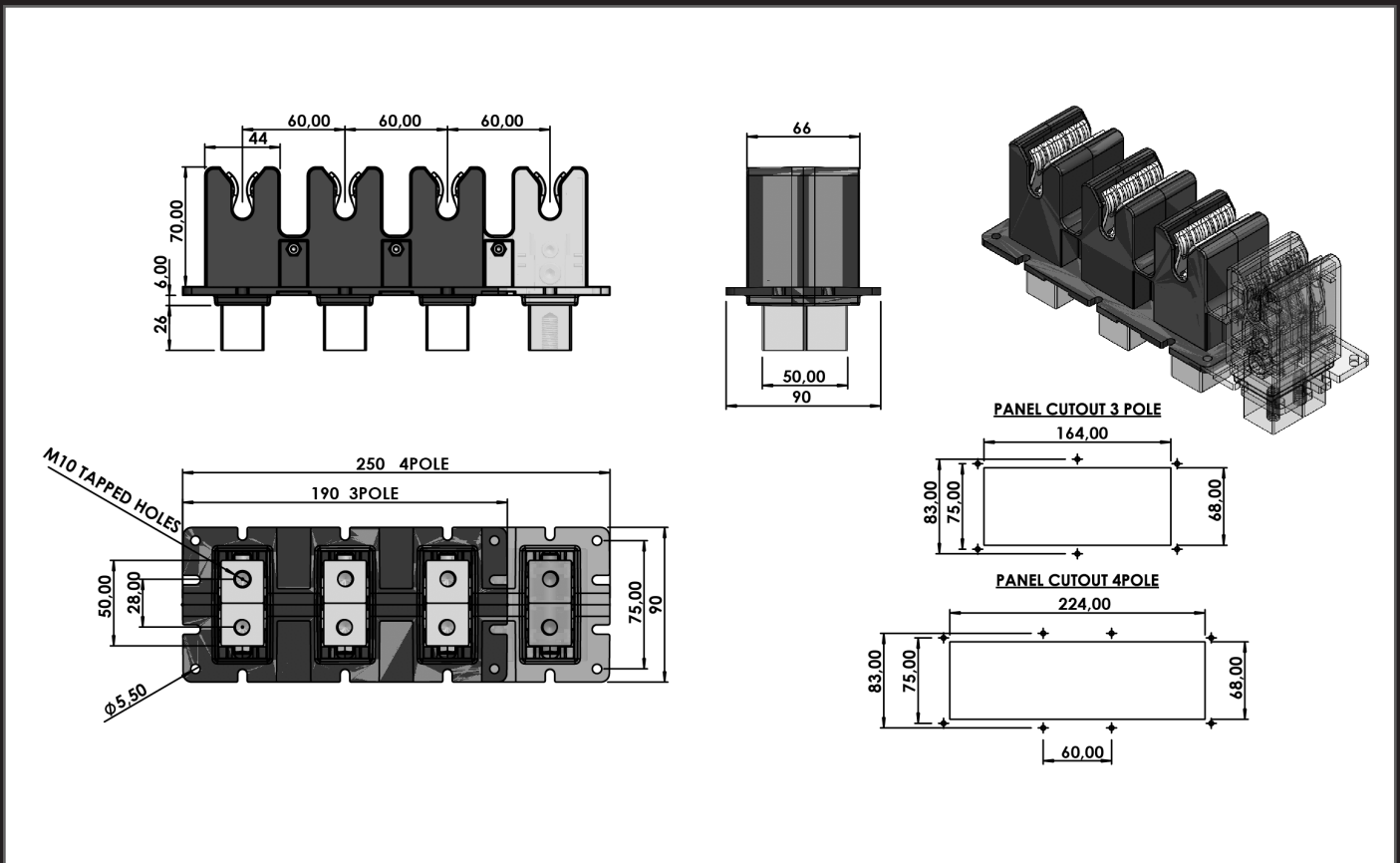

* PDF & 3D drawings are available on request.

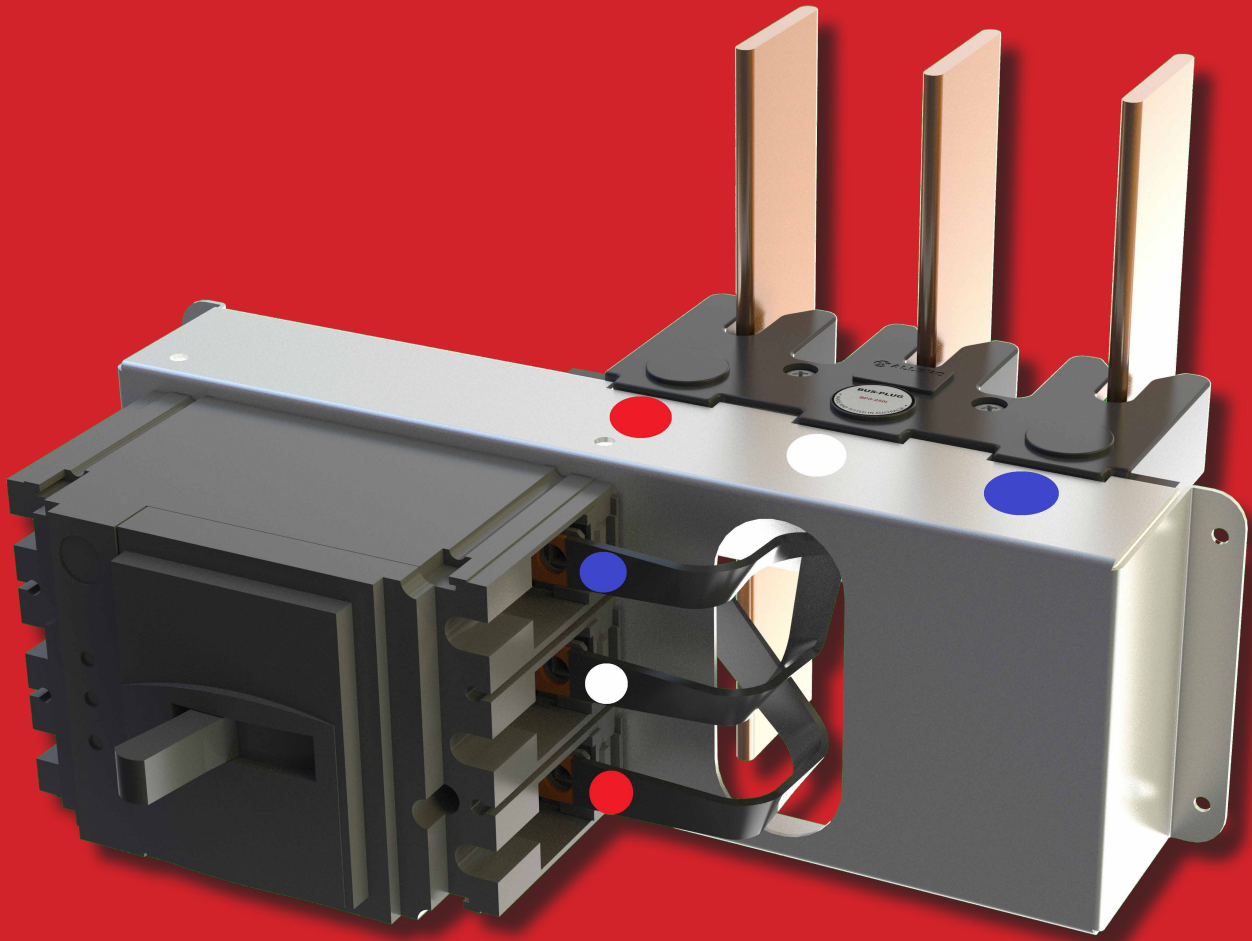

Plug in Chassis

Part Number	Description
Standard Chassis	
SBC3-125/250	Standard Breaker Chassis 3 Phase 125/250A
SBC3-250	Standard Breaker Chassis 3 Phase 250A
SBC3-400	Standard Breaker Chassis 3 Phase 400A
SBC3-630	Standard Breaker Chassis 3 Phase 630A
SBC3-NS630	Standard Breaker Chassis 3 Phase NS 630A
SBC3-800	Standard Breaker Chassis 3 Phase 800A
SBC3-NS800	Standard Breaker Chassis 3 Phase NS 800A
Offset Chassis	
OBC3-125/250	Offset Breaker Chassis 3 Phase 125/250A
OBC3-NS125/250	Offset Breaker Chassis 3 Phase NS 125/250A
OBC3-250	Offset Breaker Chassis 3 Phase 250A
OBC3-NS250	Offset Breaker Chassis 3 Phase NS 250A
OBC3-400	Offset Breaker Chassis 3 Phase 400A
OBC3-630	Offset Breaker Chassis 3 Phase 630A

Typical Layout

Available in Left or Right Hand

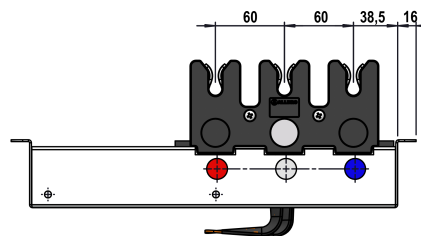

TYPE A

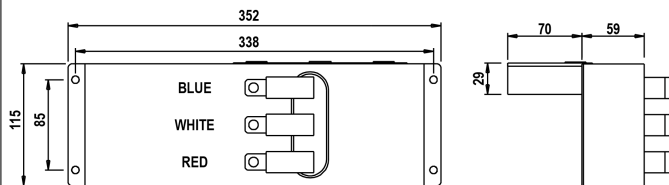

TYPE B

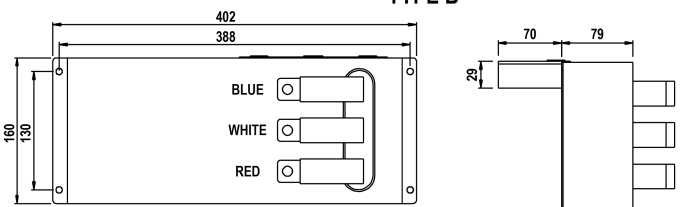

TYPE BS

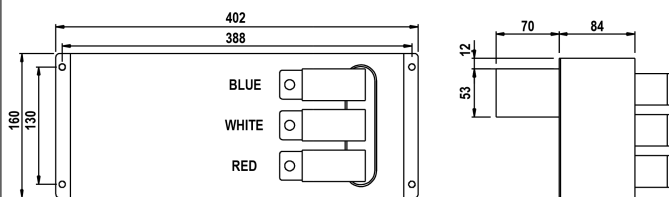

TYPE C

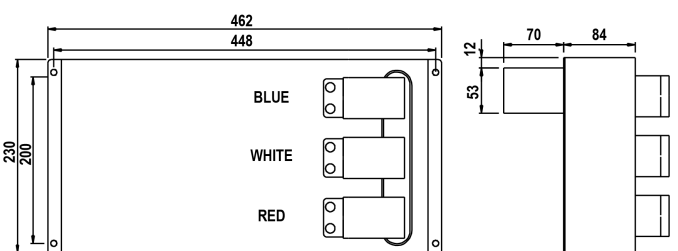

TYPE D

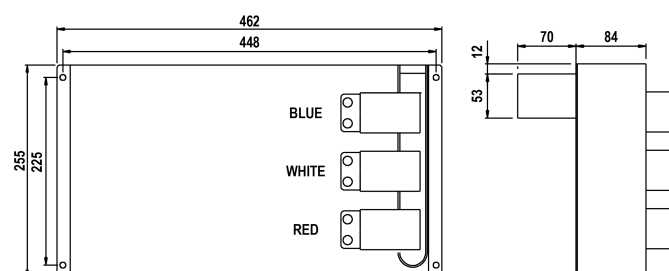

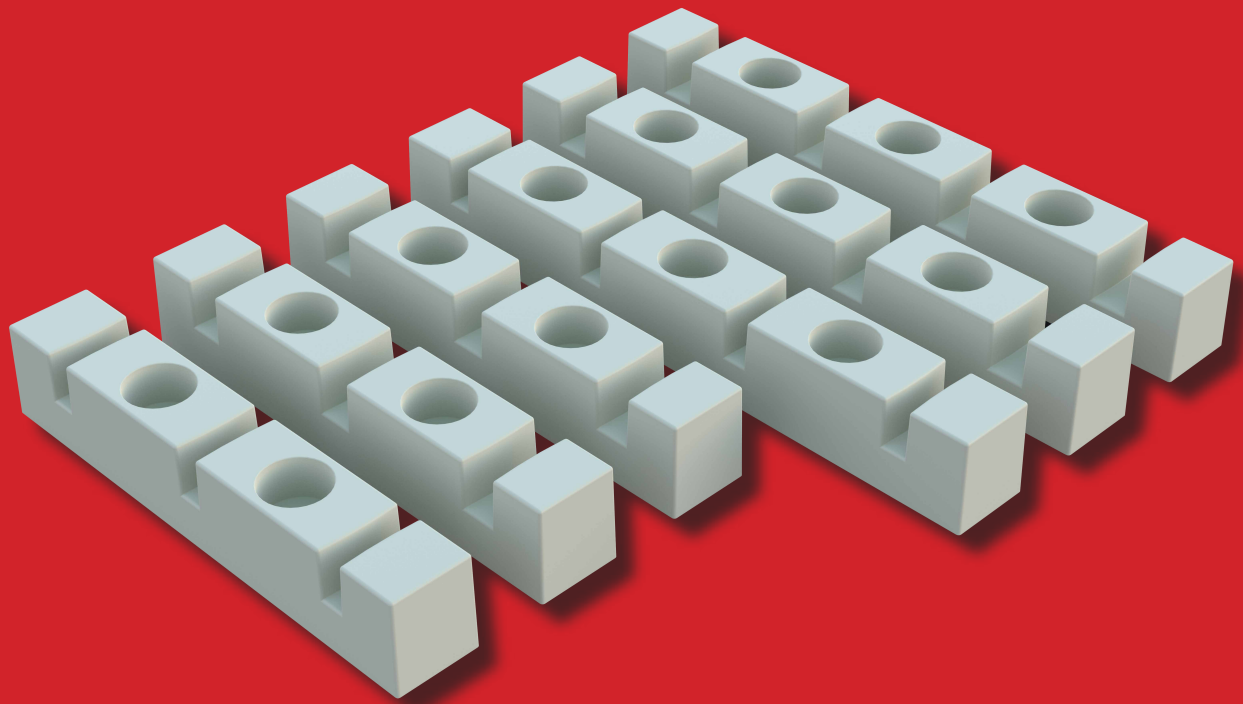

AB-Busbar Supports

Material Datasheet: SMC (Sheet Moulding Compound)

Typical Properties	Standard	Units	SMC 1-20	SMC 2-20
Density	ISO 1183	g/ccm	1.8	1.8
Fibre content	EN ISO 1172	mass-%	20	30
Fibre type			Glass	Glass
Recycling code	VDA 260		UP-GS20	UP-GS30
Recyclability	-	-	Yes	Yes
Young's modulus 1)	EN ISO 527-4	GPa	9	10.5
Tensile strength 1)	EN ISO 527-4	MPa	55	70
Tensile rupture strain 1)	EN ISO 527-4	%	1.4	1.4
Compression strength 1)	EN ISO 14126	MPa	160	160
Poisson's ratio 1)	EN ISO 527-4	-	0.3	0.3
Flex modulus 1)	EN ISO 14125	GPa	10.5	10.5
Flexural strength 1)	EN ISO 14125	MPa	150	165
Impact strength 1)	EN ISO 179	KJ/m ²	60	70
CTE 1)	ISO 11359-2	10 ⁻⁶ m/mK	18	18
Continuous service temperature	Similar to IEC 216	°C	150	150
Short term service temperature	-	°C	210	210
Heat distortion temperature	EN ISO 75-2	°C	200	200
Specific heat capacity	-	J/gK	1.1	1.1
Volume resistivity	IEC 60093	Ohm*cm	10 ¹²	10 ¹²
Surface resistivity	IEC 60093	Ohm	10 ¹⁴	10 ¹⁴
Comparative tracking index	IEC 60112	CTI	600	600
Dielectric strength	IEC 60243-1	kV/mm	25	25
Dielectric constant	IEC 60250	-	4.5	4.5
Dissipation factor	IEC 60250	-	0.01	0.01
Oxygen index	EN ISO 4589-2	%	22	22
Flammability	UL94	Level/thickness	V0/3.2mm	V0/3.2mm
Flammability	ISO 3795	Class/thickness	NBR/3.2mm	NBR/3.2mm
Fire/smoke	EN 45545	Hazard Level	-	-
Glow bar	IEC 60707	Level	BH2-95	BH2-95
Glow wire	IEC 60965-2-1	°C	960	960
Water absorption	ISO 62	% after 24h	<0.3	<0.3

Part Number	Description	Number of Poles	Slot Width (mm)	Fixing Bolt Size (mm)
AB3-6.35	AB Busbar support 3W-6.3mm slots	3	6.35	2 x M6
AB3-8	AB Busbar support 3W-8mm slots	3	8	2 x M6
AB3-10	AB Busbar support 3W-10mm slots	3	10	2 x M6
AB3-12	AB Busbar support 3W-12mm slots	3	12	2 x M6
AB4-6.35	AB Busbar support 4W-6.3mm slots	4	6.35	4 x M6
AB4-8	AB Busbar support 4W-8mm slots	4	8	4 x M6
AB4-10	AB Busbar support 4W-10mm slots	4	10	4 x M6
AB4-12	AB Busbar support 4W-12mm slots	4	12	4 x M6

Support Spacings

Fault Current (kA)	I _{pk}			
	66	105	143	176
	I _{rms}			
	30	50	65	80
Busbar size (mm)				
6.35mm Busbars				
40 x 6.35	600	-	-	-
50 x 6.35	650	240	-	-
63 x 6.35	700	250	200	-
80 x 6.35	750	260	210	140
100 x 6.35	800	280	260	150
125 x 6.35	800	300	300	150
10mm Busbars				
40 x 10	550	320	230	-
50 x 10	600	340	240	-
60 x 10	700	360	250	130
80 x 10	800	380	260	140
100 x 10	800	400	280	150
120 x 10	800	400	290	150

- Tests are in accordance with AS/NZS 61439.1:2016, Clause 10.11.5.3.3
- Test voltage: 415V 50Hz for a duration of 1 sec
- Tests have been carried out on a standard switchboard enclosure to comply with clause 10.11.5.1

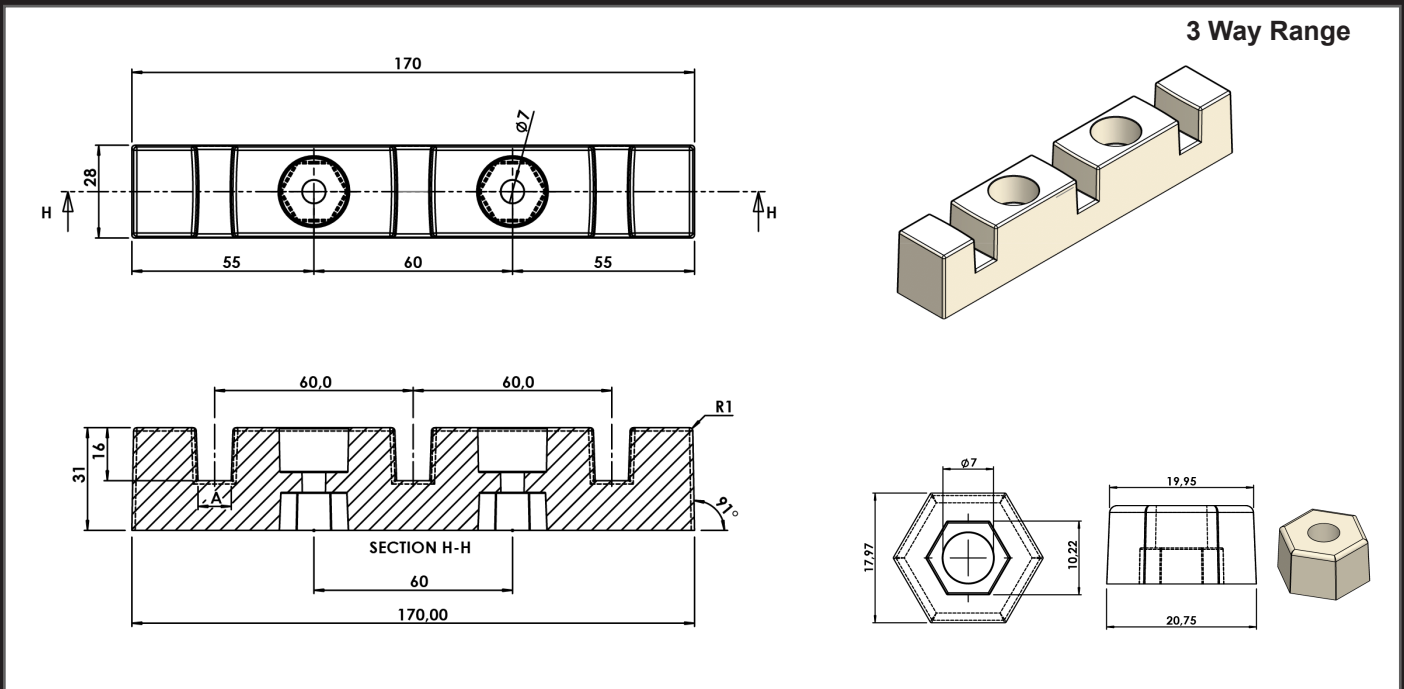

* PDF & 3D drawings are available on request.

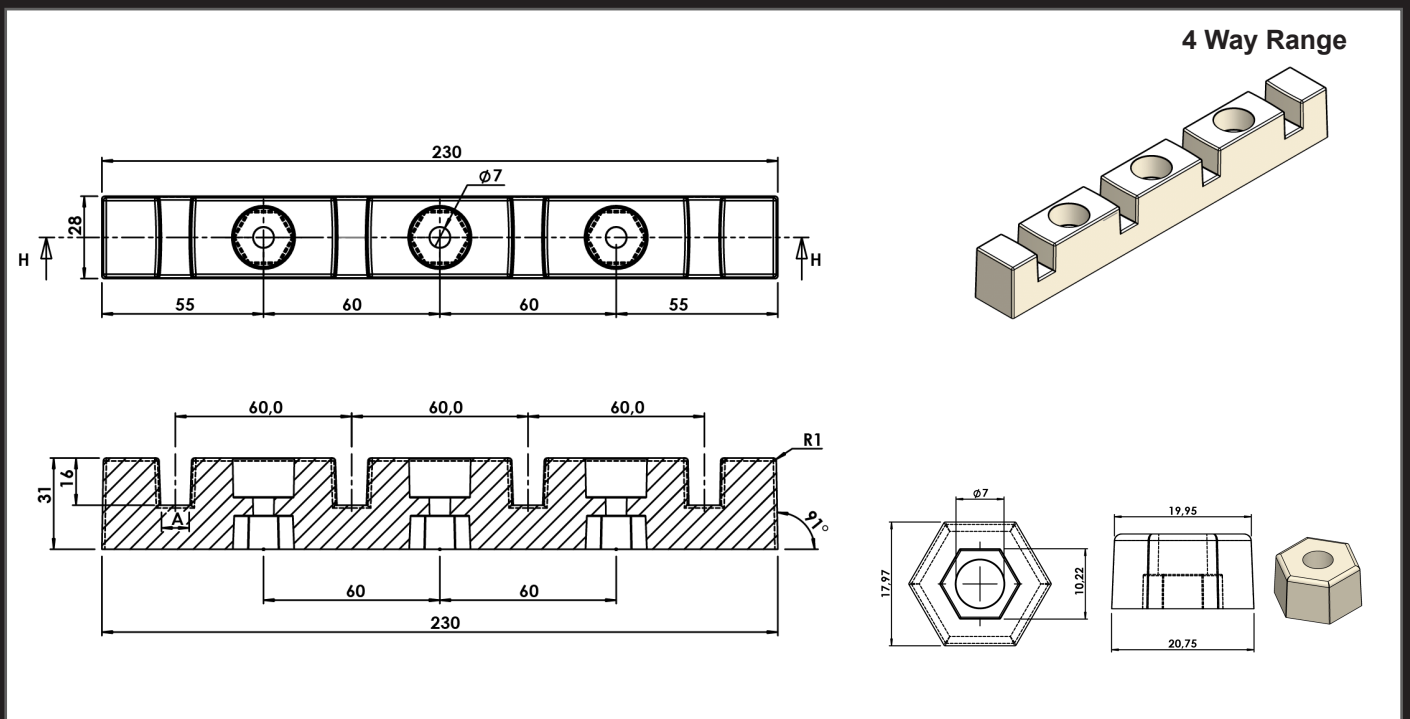

* PDF & 3D drawings are available on request.

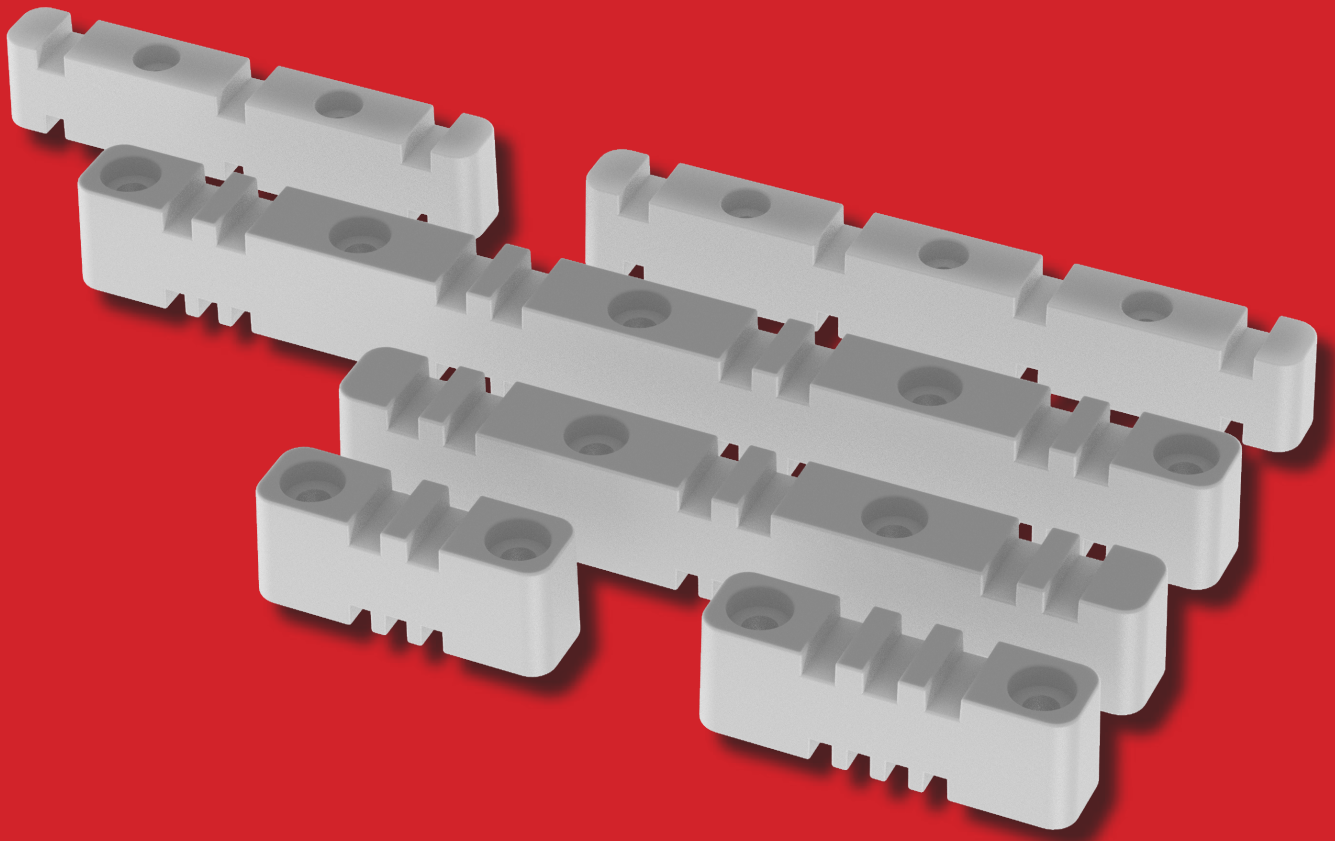

ABD-Busbar Supports

Part Number	Description	Number of Poles	Side A		Side B		Fixing Bolt Size
			Number of Slots	Size of Slots (mm)	Number of Slots	Size of Slots (mm)	
ABD-1/210/306	ABD 1W-2x10/3x6 Slots	1	2	10	3	6	2 x M8
ABD-1/310/406	ABD 1W-3x10/4x6 Slots	1	3	10	4	6	2 x M8
ABD-1/312/310	ABD 1W-3x12/3x10 Slots	1	3	12	3	10	2 x M8
ABD-3/110/106	ABD 3W-1x10/1x6 Slots	3	1	10	1	6	2 x M6
ABD-4/110/106	ABD 4W-1x10/1x6 Slots	4	1	10	1	6	3 x M6
ABD-3/210/306	ABD 3W-2x10/3x6 Slots	3	2	10	3	6	2 x M8
ABD-4/210/206	ABD 4W-2x10/2x6 Slots	4	2	10	2	6	5 x M8

Support Spacings - 6.35mm

* Larger spans are possible as the phase centres are increased. Support intervals are based on 100mm phase centres.

Fault Current (kA)	1 Bar			2 > Bars		
	105	143	176	105	143	176
	50	65	80	50	65	80
	Busbar size (mm)					
ABD-1/210/306 / ABD-1/310/406 / ABD-1/312/310						
50 x 6.35	330	-	-	360	340	-
63 x 6.35	350	320	-	400	360	-
80 x 6.35	400	350	190	420	380	200
100 x 6.35	420	360	190	450	380	200
125 x 6.35	420	360	200	450	380	220
160 x 6.35	420	360	220	450	380	240
ABD-3/110/106 / ABD-4/110/106						
40 x 6.35	-	-	-	-	-	-
50 x 6.35	280	-	-	-	-	-
63 x 6.35	290	230	-	-	-	-
80 x 6.35	300	250	-	-	-	-
100 x 6.35	320	280	-	-	-	-
ABD-3/210/306 / ABD-4/210/306						
50 x 6.35	330	-	-	360	340	-
63 x 6.35	350	320	-	400	360	-
80 x 6.35	400	350	170	420	380	200
100 x 6.35	420	360	190	450	380	200
125 x 6.35	420	360	200	450	380	220
160 x 6.35	420	360	220	450	380	240

Support Spacings - 10mm

* Larger spans are possible as the phase centres are increased. Support intervals are based on 100mm phase centres.

Fault Current (kA)	1 Bar			2 > Bars		
	105	143	176	105	143	176
	50	65	80	50	65	80
Busbar size (mm)						
ABD-1/210/306 / ABD-1/310/406 / ABD-1/312/310						
50 x 10	430	360	-	450	-	-
60 x 10	430	380	220	450	400	240
80 x 10	440	400	230	460	400	250
100 x 10	450	420	250	460	420	260
120 x 10	450	420	250	460	430	260
160 x 10	450	420	260	460	430	270
ABD-3/110/106 / ABD-4/110/106						
30 x 10	300	-				
40 x 10	320	-				
50 x 10	350	250				
60 x 10	350	270				
80 x 10	360	280				
100 x 10	380	300				
ABD-3/210/306 / ABD-4/210/306						
40 x 10	400	-	-	-	-	-
50 x 10	420	380	-	450	-	-
60 x 10	430	380	220	450	400	240
80 x 10	440	390	230	460	400	250
100 x 10	450	400	250	460	420	260
125 x 10	450	430	250	460	430	260
160 x 10	450	430	260	460	430	270

ABD1.210.306

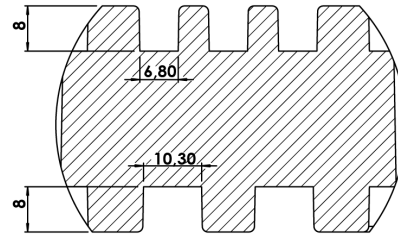
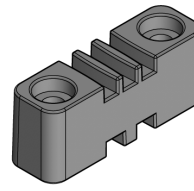
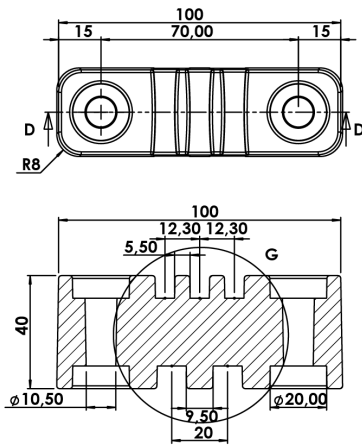

SLOTS DETAIL G

ABD1.310.406

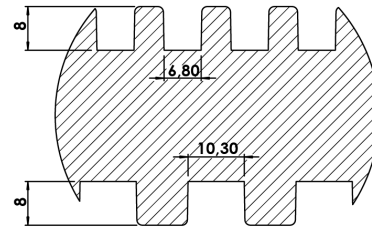
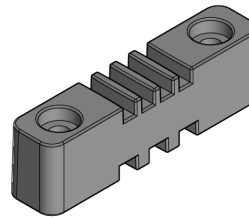
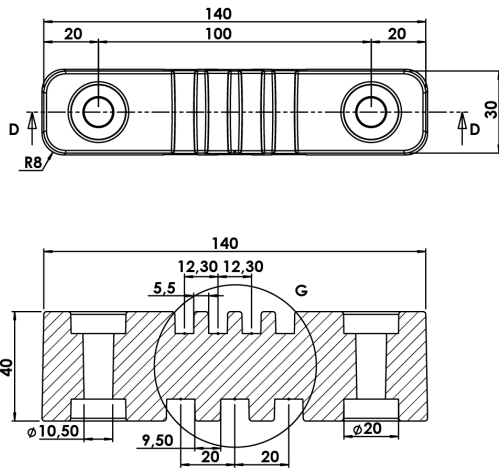

SLOTS DETAIL G

ABD1.312.310

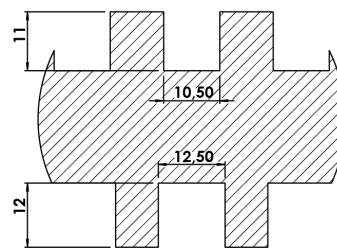
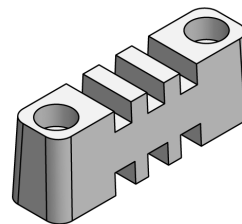
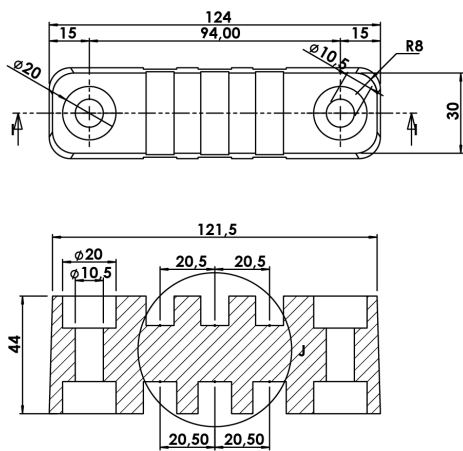

DETAIL J

SECTION I-I

* PDF & 3D drawings are available on request.

* The standard material for these busbar supports is SMC. Glass Filled Nylon is available on request.

ABD3.110.106

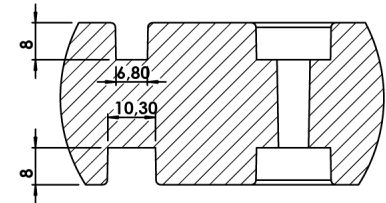
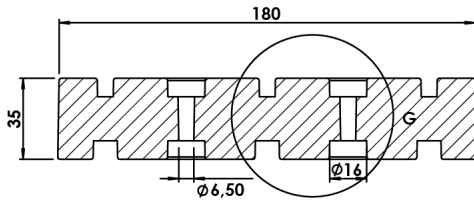
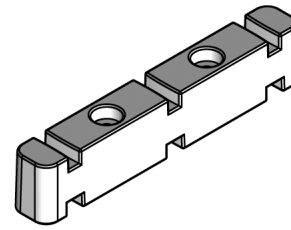
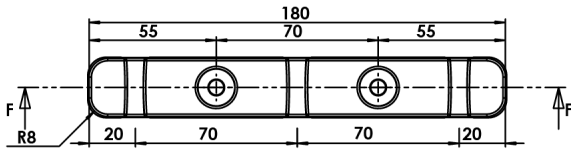

DETAIL G

ABD3.210.306

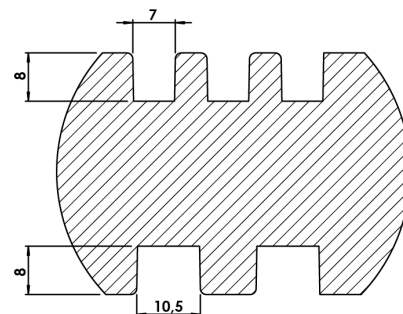
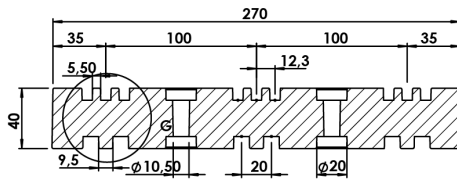
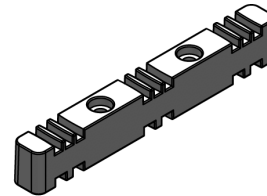
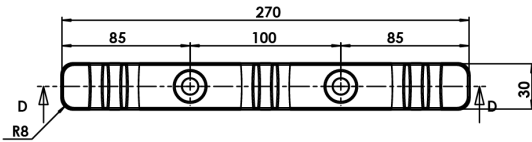

SLOTS DETAIL G

ABD4.110.106

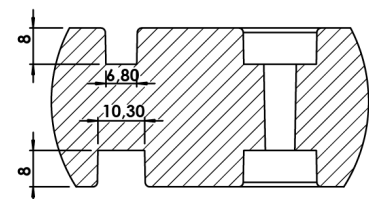
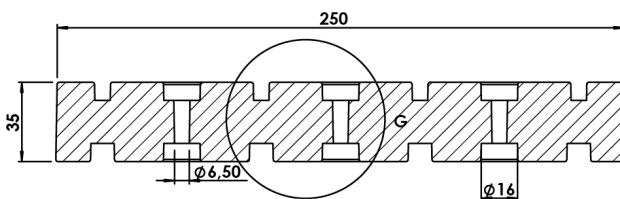
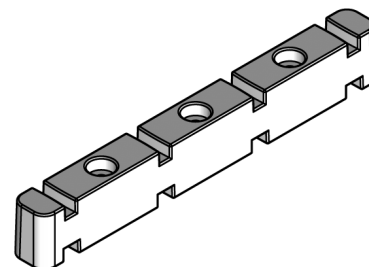
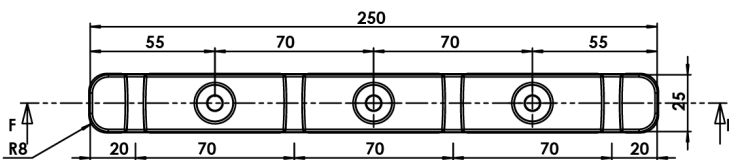

DETAIL G

* PDF & 3D drawings are available on request.

* The standard material for these busbar supports is SMC. Glass Filled Nylon is available on request.

ABD4.210.306

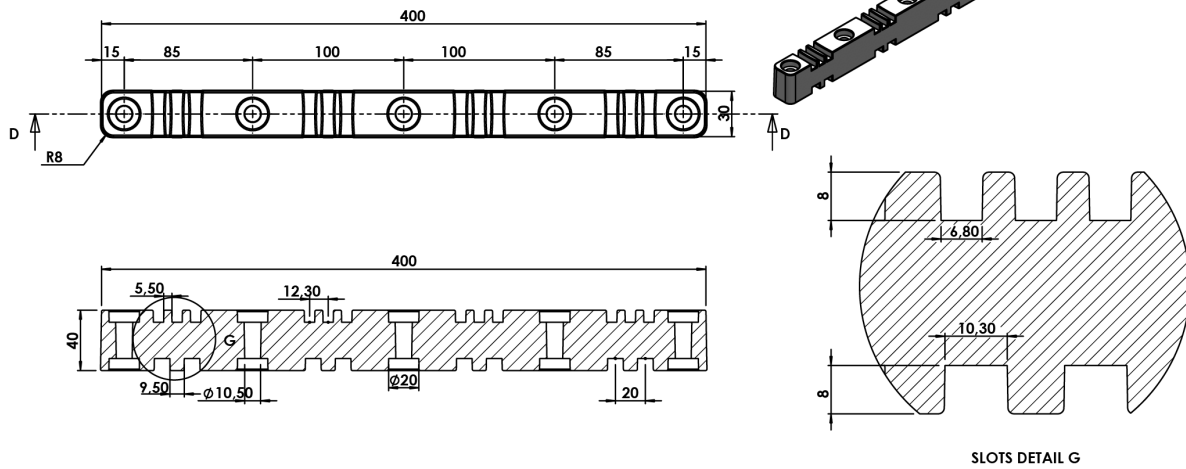

* PDF & 3D drawings are available on request.

* The standard material for these busbar supports is SMC. Glass Filled Nylon is available on request.

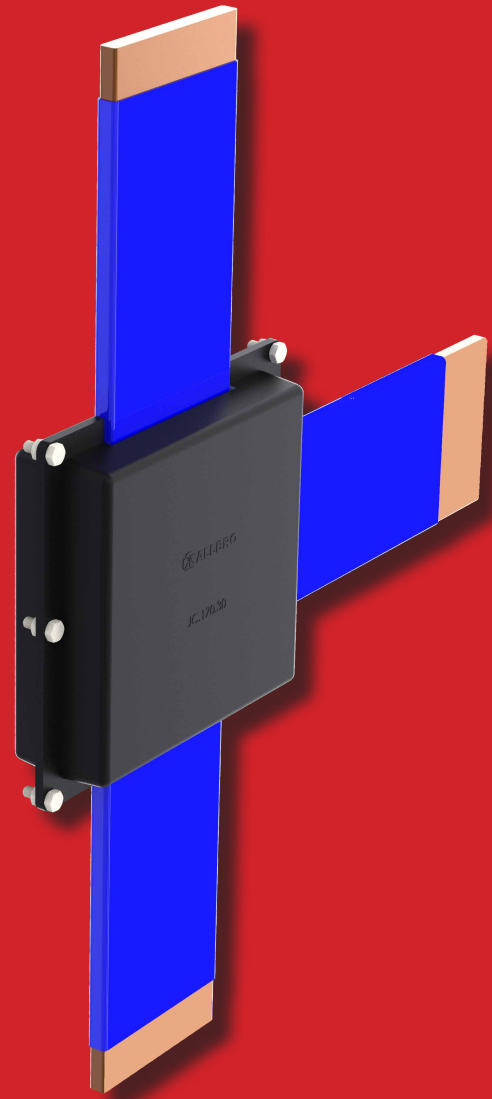

Joint Covers

Joint Covers are made from injection moulded PVC. Busbar entries are made by cutting the covers to suit. We sell mostly in Black, but Red, White and Blue covers are available on request. Made from injection moulded PVC. Joints can be customised by cutting the covers.

Specification for Insulated Busbar Covers:

- 1) Scope: Insulating shrouds suitable to cover various types of joints between two conductors for application in low & medium voltage switchgear.
- 2) Colour: Red/Black/Blue/White
- 3) Raw Material: PVC
- 4) Properties:

No.	Property	Test Method	Required Value	Observed Value
1	Flammability	UL 94-2013	Self Extinguishing (UL94-V0 Compliant)	Conforms
2	Comparative Tracking Index (CTI), Volts	IEC 60112-2003	>600	>600
3	Dielectric strength in air at 25°C kV/mm	IEC 60243-1-2013	Should withstand 36kv for 1 min. >8 kV/mm	Withstood 36kv for 1 min without puncture 9.4kV
4	Volume resistivity in air at 25°C, Ohms-cm	ASTM D257-2014	1x10 ⁹ - 1x10 ¹¹	1.9x10 ¹¹
5	Tensile strength at break, MPa	ASTM D638-2010	>10 MPa	12.5
6	Elongation at break %	ASTM D638-2010	300%	396
7	Water absorption after 24hrs immersion in water at 24°C, %	ASTM D570-1998	0,8% (Max)	0,50

Part Number	Description	Dimensions (mm)		
		A	B	C
SQUARE TYPE				
JC-90x25-BK	Joint Cover 90x25 Black	90	90	25
JC-90x45-BK	Joint Cover 90x45 Black	90	90	45
JC-135x30-BK	Joint Cover 135x30 Black	135	135	30
JC-135x50-BK	Joint Cover 135x50 Black	135	135	50
JC-170x30-BK	Joint Cover 170x30 Black	170	170	30
JC-170x50-BK	Joint Cover 170x50 Black	170	170	50
RECTANGULAR TYPE				
JC-200x100x30-BK	Joint Cover 200x100x30 Black	200	100	30
JC-200x100x50-BK	Joint Cover 200x100x50 Black	200	100	50

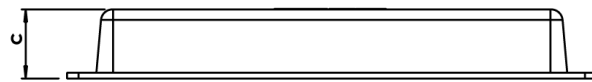
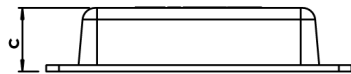
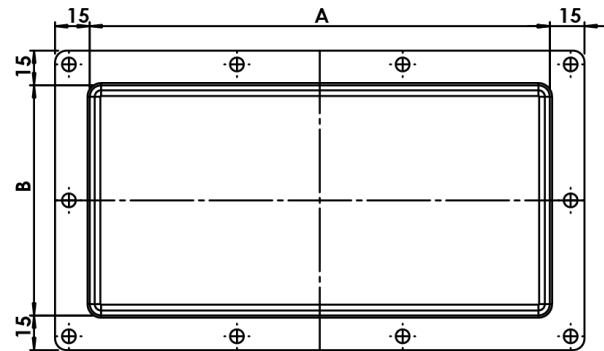
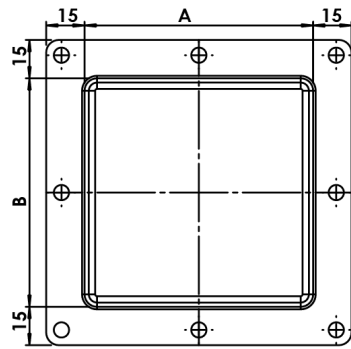

* PDF & 3D drawings are available on request.



**5 Bessemer Road
Port Kennedy WA 6172
Australia**

**Tel: +61 8 9501 9370
Fax: +61 89 463 1404
Email: enquiries@allbro.com.au
www.allbro.com.au**